

DANTHERM

COOLING

PrecisionAir® Series

Product User Manual



INTRODUCTION

This is the service manual for Dantherm PrecisionAir WS units. Please see the table of contents below for further information about the sections of this manual.

TARGET GROUP

The target group for this service manual are the technicians who install and maintain the PrecisionAir 2,000-28,000 BTU units.

COPYRIGHT

Copying of this service manual, or part of it, is forbidden without prior written permission from Dantherm Cooling Inc.

RESERVATIONS

Dantherm reserves the right to make changes and improvements to the product and the service manual at any time without prior notice or obligation.

TABLE OF CONTENTS

UNPACKING SAFETY WARNING	3
MODEL IDENTIFICATION.....	4
PRODUCT DESCRIPTION	5
MODEL OVERVIEW	6
INSTALLATION.....	7-8
OPERATIONS AND CONTROLLER	9-13
WIRING DIAGRAMS	14
UNIT OVERVIEW.....	15-35
PA 2000	15-17
PA 4000	18-20
PA 6000	21-23
PA 10000, 12000, 14000	24-26
PA 14000 MID MOUNT.....	27-29
PA 20000	30-32
PA 24/28000	33-35
MAINTENANCE SPARE PARTS	36-37
WARRANTY	38
RMA DECLARATION OF CONFORMITY.....	39

UNPACKING, HANDLING, AND INSPECTION

Thank you for purchasing a Dantherm PrecisionAir WS unit. Please carefully review all handling and installation instructions.

- HVAC systems should be maintained in an upright positions at all times to prevent refrigerator oil migration.
- While unpacking, the unit should be inspected for any damage that may have occurred during shipment.
- Damage to the unit or packaging should be immediately addressed with the shipping carrier.
- Do not attempt to operate or repair the unit if it appears to be damaged.
- Any damage as a result from mishandling is not covered under Dantherm Cooling's standard warranty.

GENERAL SAFETY

Certain parts of electrical systems are inevitably live or have a high operating temperature. Observe caution at all times.

- Failure to observe these conditions and installation instructions can cause injury and damage.
- The system is to be installed and maintained only by trained and qualified personnel.
- Do not apply power until all ground connections have been made.
- The unit is fitted with pressed and folded metal parts, which could have sheared metal edges. Be cautious handling the unit, especially when working in poorly accessible places.
- Check that no tools, test equipment, torches etc. have been left in or on the equipment on completion of work.
- Ensure the cover(s) and all mounting hardware is firmly secured before leaving installation.
- All cable and connectors must conform to UL standards.

- Most models are UL recognized and tested to UL484. It will comply where necessary within the safety requirements as defined in UL484.
- When servicing the unit, do not remove the cover(s) for 5 minutes after switching the unit off to allow pipe work (compressor discharge) to cool.

WARNINGS

INTRODUCTION: This installation manual and the product uses various displays and labels to ensure safe use. Ignoring these displays and labels and incorrectly using the product could have results as classified below. Please read the following warning symbol information before reading the rest of this section, and be sure to strictly observe all instructions.

GENERAL PRECAUTION: This appliance is not intended for use by persons (including children) with reduced physical, sensory or mental capabilities, or lack of experience and knowledge, unless they have been given supervision or instruction concerning use of the appliance by a person responsible for their safety. Children should be supervised to ensure that they do not play with the appliance. If the power cord is damaged, it must be replaced by the manufacturer, a service agent, or a similar qualified person in order to avoid a hazard.

 **WARNING:** Not following these instructions could result in death or serious injury.

 **CAUTION:** Not following these instructions could result in injury or property damage.

 This symbol will show for something that should NOT be done.

Project safety is your responsibility! Follow the instructions in this manual regarding the installation method and installation orientation. Not following these instructions could result in injury, death, or damage to equipment. All work should be performed by qualified personnel using safe work practices. All proper protective equipment should be used. PPE required may include, but is not limited to: Safety glasses | Hard hat | Safety shoe | Hearing protection | Cut resistant gloves | Face shield | Proper work attire (long sleeve shirt and long pants)

MODEL IDENTIFICATION

PA-10-230-ET-SS-04

CAPACITY
4 - 4000 BTU
6 - 6000 BTU
10 - 10000 BTU
12 - 12000 BTU
14 - 14000 BTU
24 - 24000 BTU
28 - 28000 BTU

VOLTAGE
115 - 115 VAC
230 - 230 VAC
48 - 48 VDC

OPTIONAL METAL PACKAGE
SS - STAINLESS STEEL*
*LEAVE BLANK - STANDARD GALVANIZED STEEL

OPTIONAL ETHERNET CONTROLLER
ET - ETHERNET CONTROLLER

COLOR
04 - P04 BEIGE
20 - P20 WHITE
00 - P00 CUSTOM

Color Options

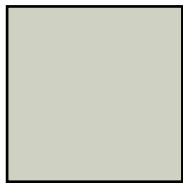

04 - P04 Beige



20 - P20 White

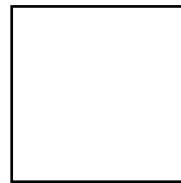

00 - P00 Custom

PROUCT DESCRIPTION

The PrecisionAir series is designed to control the internal temperature of an enclosure. by removing dissipated heat from inside the structure and is designed to maintain accurate temperatures for electronic equipment.

IMPORTANT

Dantherm Cooling Inc. recommends that the cooling system should run continuously.

FUNCTIONALITY

The illustration to the right shows the airflow of the air conditioner. The two air flows (internal/external) operate separately. External air is only used to cool down the condenser which dissipates the heat absorbed by the indoor evaporator. The air flows are not mixed.

INTERNAL AIR FLOW

Warm, internal air is drawn into the unit by the internal evaporator fan. The air is then pushed through the evaporator, and then released into the enclosure through the evaporator opening.

EXTERNAL AIR FLOW

Cold, external air is drawn into the unit by the condenser fan, and then routed through the condenser, where it is cooled. After passing through the condenser, the air is returned to the external environment.

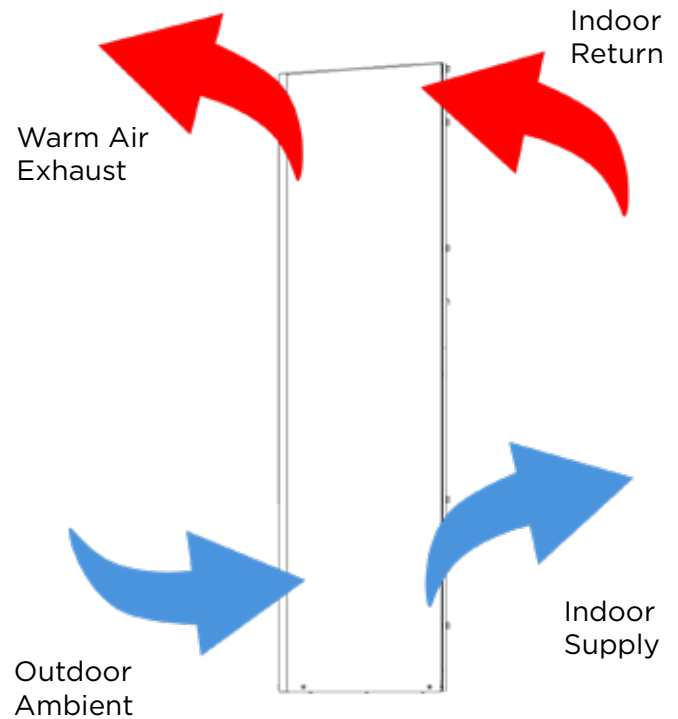

MODEL OVERVIEW					
PA	ENCLOSURE SIZE INCHES [MM] H X W X D	COOLING CAPACITY/BTU	HEATER POWER/WATT	VOLTAGE / FREQUENCY	EXTERNAL OVER CURRENT PROTECTION
PA-2-115	20.25x10.4x10.6 [737x439x286]	2,000	1,000	115V/ 50-60 Hz	10A
PA-2-230	20.25x10.4x10.6 [737x439x286]	2,000	1,000	230V/ 50-60 Hz	10A
PA-4-115	29x17.3x11.3 [737x439x286]	4,000	1,000	115V/ 50-60 Hz	15A
PA-4-230	29x17.3x11.3 [737x439x286]	4,000	1,000	230V/ 50-60 Hz	15A
PA-4-460/3	29x17.3x11.3 [737x439x286]	4,000	1,000	460/3 60 Hz	10A
PA-4-48	29x17.3x11.3 [737x439x286]	4,000	500	48 VDC	20A
PA-6-115	29x17.3x11.3 [737x439x286]	6,000	1,000	115V/ 50-60 Hz	15A
PA-6-230	29x17.3x11.3 [737x439x286]	6,000	1,000	230V/ 50-60 Hz	15A
PA-6-460/3	29x17.3x11.3 [737x439x286]	6,000	1,000	460V/3 50-60 Hz	10A
PA-6-48	29x17.3x11.3 [737x439x286]	6,000	500	48 VDC	20A
PA-10-230	47.3x19.3x12.2 [1201x490x309]	10,000	2,000	230V/ 50-60 Hz	15A
PA-10-48	47.3x19.3x12.2 [1201x490x309]	10,000	500	48 VDC	30A
PA-24-230	59x24.3x20.2 [1513x618x514]	24,000	2,000	230V/ 50-60 Hz 48 VDC	ACV 30A VDC 2x 30A*
PA-24-48	59x24.3x20.2 [1499x617x513]	24,000	1,000	48 VDC	48 VDC
PA-28-48	59x24.3x20.2 [1513x618x514]	28,000	2000 VAC 1000 VDC	48 VDC	ACV 30A VDC 2x 30A*

***NOTE**

The PrecisionAir 24,000 and 28,000 48 VDC units feature two redundant electrical systems

and require two circuits with individual over-current protection of 30A each.

INSTALLATION

Please strictly observe the following:

Special skills are required to install Dantherm products. Non-qualified personnel should not attempt any of the actions shown in this installation guide. Dantherm shall not be responsible for improper installation or any accidents, damages, or injury resulting from improper installation.

These units are designed to be mounted outdoor, flush to the wall. Any other installation method is not recommended.

⚠ WARNING

Never carry out any installation, maintenance or service, without disconnecting the power supply.

INSTALLATION PLACEMENT

Any installation should allow good air flow inside the enclosure. The unit has cold temperature supply in the lower part and return air in the upper part of the unit. Please consider how to achieve the best possible air flow when selecting appropriate placement. Any installation should be finished with a proper Polymer sealing outside to prevent any water intrusion.

Lift the unit into the cutouts and place it on the hanging brackets, if applicable. Place the bolt from the inside and secure them one by one, taking great care that no damage is done to the unit or enclosure due to the small variation in enclosure structure. The maximum torque is 120in.-lbs with a recommended assembly torque of 75in.-lbs. For the 24,000 and 28,000 ACV/DCV units, the max torque is 130in.-lbs with a recommended assembly torque of 75in.-lbs.

After fastening all of the bolts, the unit should be sealed on the outside, top and side junctions towards the enclosure.

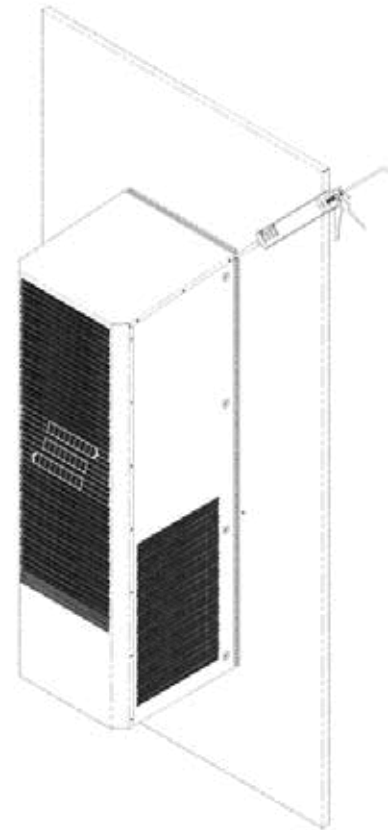

ELECTRICAL REQUIREMENTS

Please incorporate the following imperative requirements when installing the electrical connections:

WARNING

Any installation should always be in accordance with national wiring regulations, DC / AC external supply should be protected, with an external disconnecting device that has a contact separation of at least 3 mm. This external DC / AC supply must also be over current protected. These disconnecting devices, must always be labeled, with rated voltage as well as rated current.

- The units earth connections must always be connected to the enclosures ground.
- All cables, in a permanent installation, are imperative to install and secure properly to prevent any damage to equipment and/or humans. Secure all cables with cable ties or appropriate cable fasteners, made for this purpose.

ELECTRICAL CONNECTIONS

After successful unit installation, the electrical connections will be completed, after following the below requirements:

WARNING

1. The power and/or additional connections need to be routed, secured and connected to appropriate sources. The PrecisionAir unit is either delivered with:
 - 10ft. cable with stripped wires are to be connected inside a distribution board. Refer to wiring diagrams for connections.
 - Unit types with extension “-L” on the label are delivered with a factory fitted plug, that should be connected to the fused power.
 - -48 DCV units are supplied with a harness that should be connected to the fused power.
2. Connect the PrecisionAir units ground terminal to enclosure grounding.
3. All power supply connections are to be secured with an external disconnection device, as well as over current protected.
4. Connect any needed accessories.

ELECTRONIC CONTROL DESCRIPTION

This section describes key features of the optional ACG7 controller, and how it operates.

⚠ WARNING

Never carry out any installation, maintenance or service, without disconnecting the power supply.

EMBEDDED CONTROLLER

The built in all in one controller, controls the unit in the most efficient way. Basic parameters can be set via on board control panel, from inside the enclosure. Extended parameter settings, as well as, logging of operation data, is possible through the SD card interface.

CONTROL STRATEGY

The controller regulates the fans heater, and cooling based on desired set points.

- When operating, the evaporator fans will circulate the indoor air continually.
- When temperature in the enclosure is higher than set-point the compressor will start, which initiates cooling.
- The compressor will stop once set-point and hysteresis is achieved.
- A high temperature alarm (when temp is higher than 50° C) will initiate an alarm on the alarm output.
- Low temperature alarm (when temp is lower than 1° C) will initiate an alarm on the alarm output.
- The condenser fan operates only when the actual temperature on the condenser surface requires this operation.

OPERATION PANEL

The below illustrates the operation panel, from inside the enclosure.

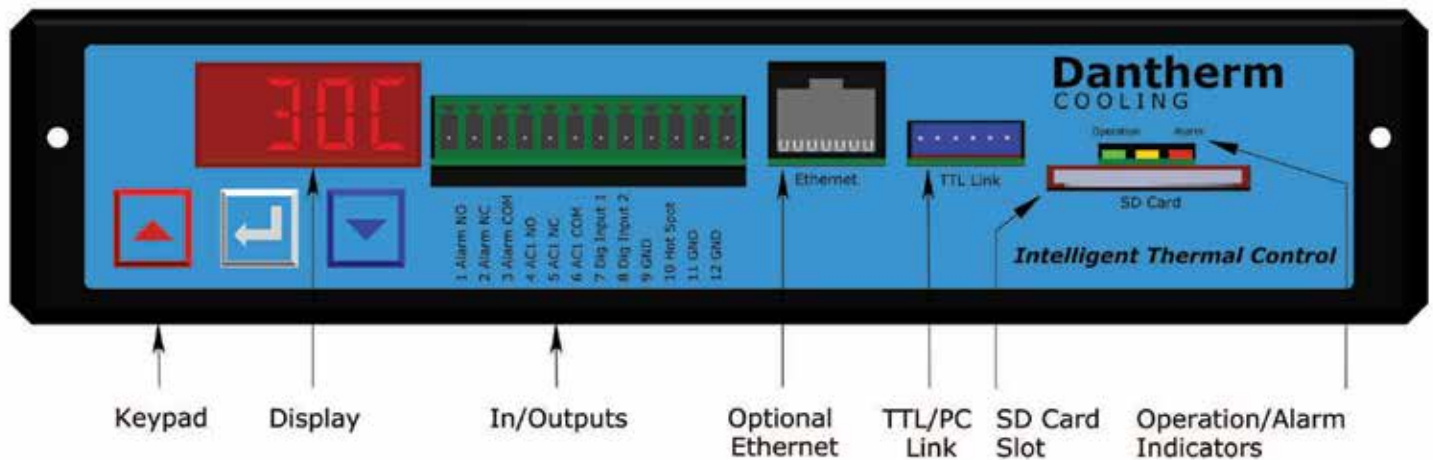

CONNECTIONS

The control board is placed internally alongside the edge of the unit's enclosure. This allows the internal connections to be inserted to the internal board. This reveals the external connections through the cut out in the sheet metal front plate.

CONNECTIONS ILLUSTRATIONS

This illustration shows the external connections to the controller.

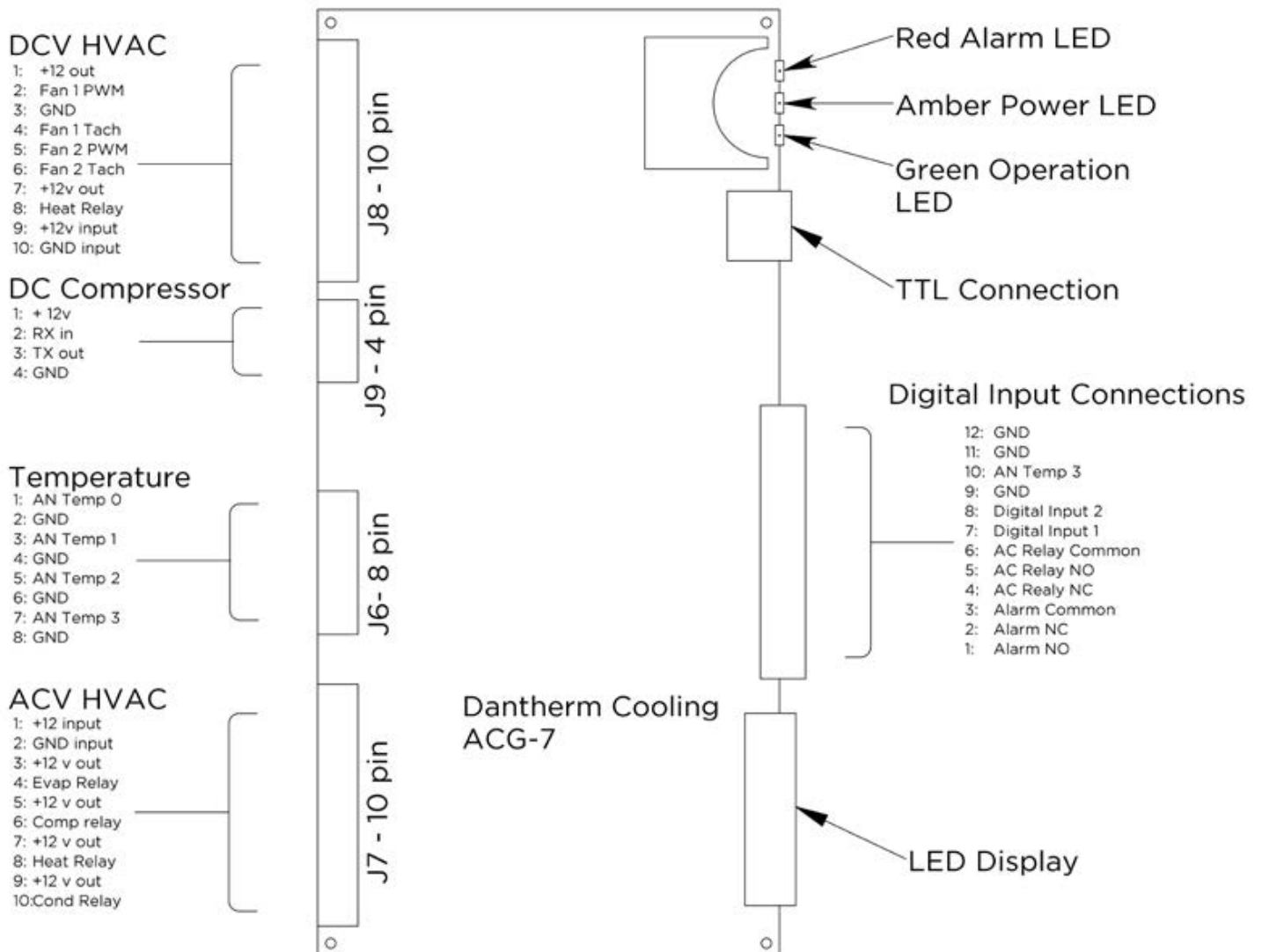

CONNECTIONS

The air conditioner can operate as a standalone cooling system if you connect it to the proper electrical cord and use the operation panel on the front of the controller. For enhanced usage, it is possible to connect an external display with keypad.

CONNECTION	USAGE	SPECIFICATION																																																																																
ALARM 1, 2, 3	This output will toggle open/ close if any operation errors occurs on the 4000 and 10,000 units. Default open or default close can be set via a jumper on the PCB. Factory setting is normally open for the 2000, 6000 and 24-28,000 units only.	Potential Free Max. 42 ACV or 60 DCV. / 500mA Galvanic Isolated (500V)																																																																																
AC 4, 5, 6	This output will toggle lead/lag function of second HVAC. Additional instructions are available on the 4000 unit only. This output will toggle open/close if the highest temperature setpoint is exceeded on the 2000, 6000, 10,000 and 24-28,000 units	Potential Free Max. 42 ACV or 60 DCV. / 500mA Galvanic Isolated (500V)																																																																																
DIGITAL INPUT 7, 9	This input can control and overrule some operation parameters. See more in the parameters list.	0/12 DCV Max. 10mA																																																																																
DIGITAL INPUT 8, 9	This input can control and overrule some operation parameters. See more in the parameters list.	0/12 DCV Max. 10mA																																																																																
HOTSPOT SENSOR 9, 10	This is the temperature sensor for placing inside the enclosure. It can be placed in a hotspot zone, if required.	NTC -30 to 85°C (-22 to 185 °F)																																																																																
COOL (Cool)	Press the “up” or “down” key to change the “compressor on” temperature. Pressing “enter” returns to the main display. After 30 seconds of no action, it will revert to the main display.																																																																																	
HEAT (HEAT)	Press the “up” or “down” key to change the “compressor on” temperature. Pressing “enter” returns to the main display. After 30 seconds of no action, it will revert to the main display.																																																																																	
TEST (tEst)	<p>Press the “up” or “down” key to change the “compressor on” temperature. Pressing “enter” returns to the main display. After 4 minutes of no action, it will revert to the main display.</p> <table border="1"> <thead> <tr> <th>Step</th> <th>Evap</th> <th>Cond</th> <th>AC</th> <th>Heater</th> <th>DC Fan 1 (evap)</th> <th>DC Fan 2 (cond)</th> <th>DC comp</th> </tr> </thead> <tbody> <tr> <td>0</td> <td>off</td> <td>off</td> <td>off</td> <td>off</td> <td>off</td> <td>off</td> <td>off</td> </tr> <tr> <td>1</td> <td>on</td> <td>off</td> <td>off</td> <td>off</td> <td>off</td> <td>off</td> <td>off</td> </tr> <tr> <td>2</td> <td>on</td> <td>off</td> <td>off</td> <td>off</td> <td>off</td> <td>off</td> <td>off</td> </tr> <tr> <td>3</td> <td>on</td> <td>on</td> <td>on</td> <td>off</td> <td>off</td> <td>off</td> <td>off</td> </tr> <tr> <td>4</td> <td>on</td> <td>on</td> <td>off</td> <td>off</td> <td>off</td> <td>off</td> <td>off</td> </tr> <tr> <td>5</td> <td>on</td> <td>off</td> <td>off</td> <td>on</td> <td>100%</td> <td>off</td> <td>off</td> </tr> <tr> <td>6</td> <td>off</td> <td>off</td> <td>off</td> <td>off</td> <td>100%</td> <td>100%</td> <td>off</td> </tr> <tr> <td>7</td> <td>off</td> <td>off</td> <td>off</td> <td>off</td> <td>100%</td> <td>100%</td> <td>100%</td> </tr> <tr> <td>8</td> <td>off</td> <td>off</td> <td>off</td> <td>off</td> <td>off</td> <td>off</td> <td>off</td> </tr> </tbody> </table>		Step	Evap	Cond	AC	Heater	DC Fan 1 (evap)	DC Fan 2 (cond)	DC comp	0	off	off	off	off	off	off	off	1	on	off	off	off	off	off	off	2	on	off	off	off	off	off	off	3	on	on	on	off	off	off	off	4	on	on	off	off	off	off	off	5	on	off	off	on	100%	off	off	6	off	off	off	off	100%	100%	off	7	off	off	off	off	100%	100%	100%	8	off	off	off	off	off	off	off
Step	Evap	Cond	AC	Heater	DC Fan 1 (evap)	DC Fan 2 (cond)	DC comp																																																																											
0	off	off	off	off	off	off	off																																																																											
1	on	off	off	off	off	off	off																																																																											
2	on	off	off	off	off	off	off																																																																											
3	on	on	on	off	off	off	off																																																																											
4	on	on	off	off	off	off	off																																																																											
5	on	off	off	on	100%	off	off																																																																											
6	off	off	off	off	100%	100%	off																																																																											
7	off	off	off	off	100%	100%	100%																																																																											
8	off	off	off	off	off	off	off																																																																											
ERR (Err)	<p>Display the error code if there is an error. If no error is present, this is not shown.</p> <table border="1"> <tbody> <tr> <td>5</td> <td>High / Low temp</td> <td>9</td> <td>Return Sensor</td> </tr> <tr> <td>6</td> <td>DC Fan 1</td> <td>10</td> <td>Hotspot Sensor</td> </tr> <tr> <td>7</td> <td>DC Fan 2</td> <td>13</td> <td>Condensor Sensor</td> </tr> <tr> <td>8</td> <td>DC Comp</td> <td>16</td> <td>High Pressure</td> </tr> </tbody> </table>		5	High / Low temp	9	Return Sensor	6	DC Fan 1	10	Hotspot Sensor	7	DC Fan 2	13	Condensor Sensor	8	DC Comp	16	High Pressure																																																																
5	High / Low temp	9	Return Sensor																																																																															
6	DC Fan 1	10	Hotspot Sensor																																																																															
7	DC Fan 2	13	Condensor Sensor																																																																															
8	DC Comp	16	High Pressure																																																																															
UNIT (unit)	Toggle between “C” and “F”. Set points will change on the display accordingly. The TTL display will remain in Celsius. After 30 seconds of no action, it will revert to the main display.																																																																																	

OPTIONAL LEAD/LAG CONNECTIONS

The PrecisionAir 24,000 and 28,000 48V DC units feature two fully redundant cooling systems including individual controllers. The controllers can be configured to function as a lead/lag system by connecting the front digital inputs as indicated.

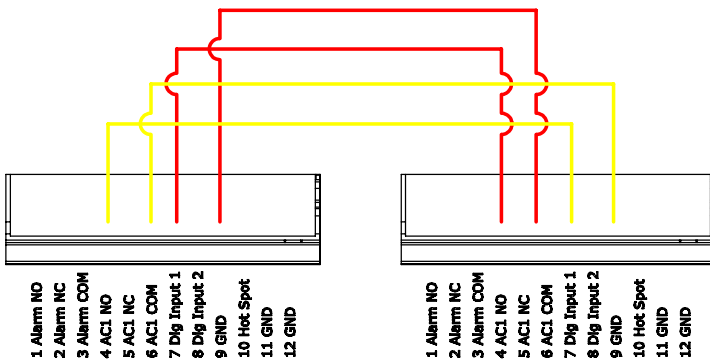
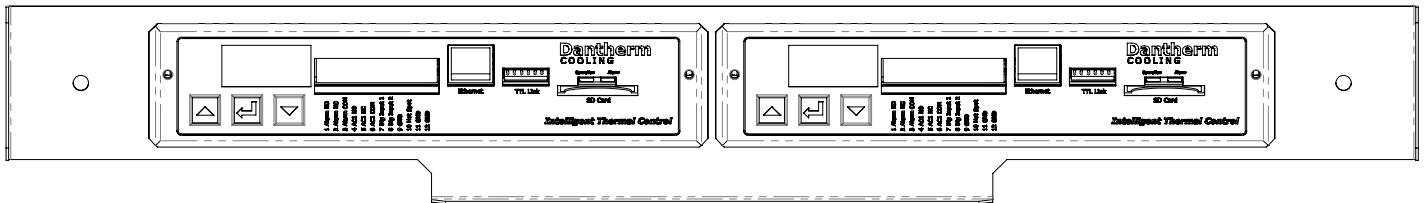

WIRING:

- PIN 4 TO 7 - YELLOW 20 AWG
- PIN 6 TO 9 - YELLOW 20 AWG
- PIN 7 TO 4 - RED 20 AWG
- PIN 9 TO 6 - RED 20 AWG

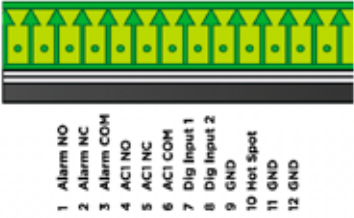
<p>CONNECTIONS</p>	 <p>1 Alarm NO 2 Alarm NC 3 Alarm COM 4 ACT NO 5 ACT NC 6 ACT COM 7 Dig Input 1 8 Dig Input 2 9 GND 10 Hot Spot 11 GND 12 GND</p> <p>FORM "C" ALARM: Connect to 1 & 3 for "Open" during alarm, "Close" during normal operation. Connect 2 & 3 for "Closed" during alarm, "Open" during normal operation.</p> <p>AC OUTPUT: Connect to 4 & 6 for controlling external air conditioner. See separate document for lead/ lag operation.</p> <p>DIG INPUT 1: When 7 & 9 are connected, until will cool in override mode. See sperate document for lead/ lag operation.</p> <p>DIG INPUT 2: For use with a door switch to interrupt operation of the unit.</p> <p>HOT SPOT SENSOR: Connect Dantherm Cooling sensor to 10 & 11 for remote sensing operation.</p>
<p>SD CARD / DATA LOGGING</p>	<p>An SD card can be inserted into the controller for automatic data logging. The data file will be labeled "log.txt". This is useful for capturing field related issues over time. The card must be a 32GB or smaller, SD or SDHC. Larger sizes and SDXC are not supported. If needed, a heading of the log file ("loghdr.txt") can be obtained by contacting technical support, which assists in identifying the fields.</p>
<p>TTL LINK / ETHERNET</p>	<p>For factory use.</p>

OPERATION

The ACG-7 uses a keypad style that uses operator interface to navigate menus, control operations, and view alarms.

KEY OPERATION

The functionality on the control panel is as follows:

- Left key is step up
- Right key is step down
- Middle key is select

NAVIGATING MENU

Menu structure and navigation. Step up/down to jump through menus, press enter to select the parameter to read or change.

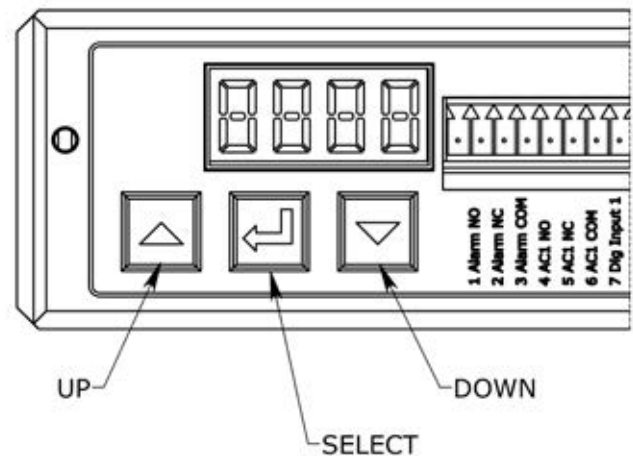

See wiring diagrams on the following page.

WIRING DIAGRAMS

230 VAC

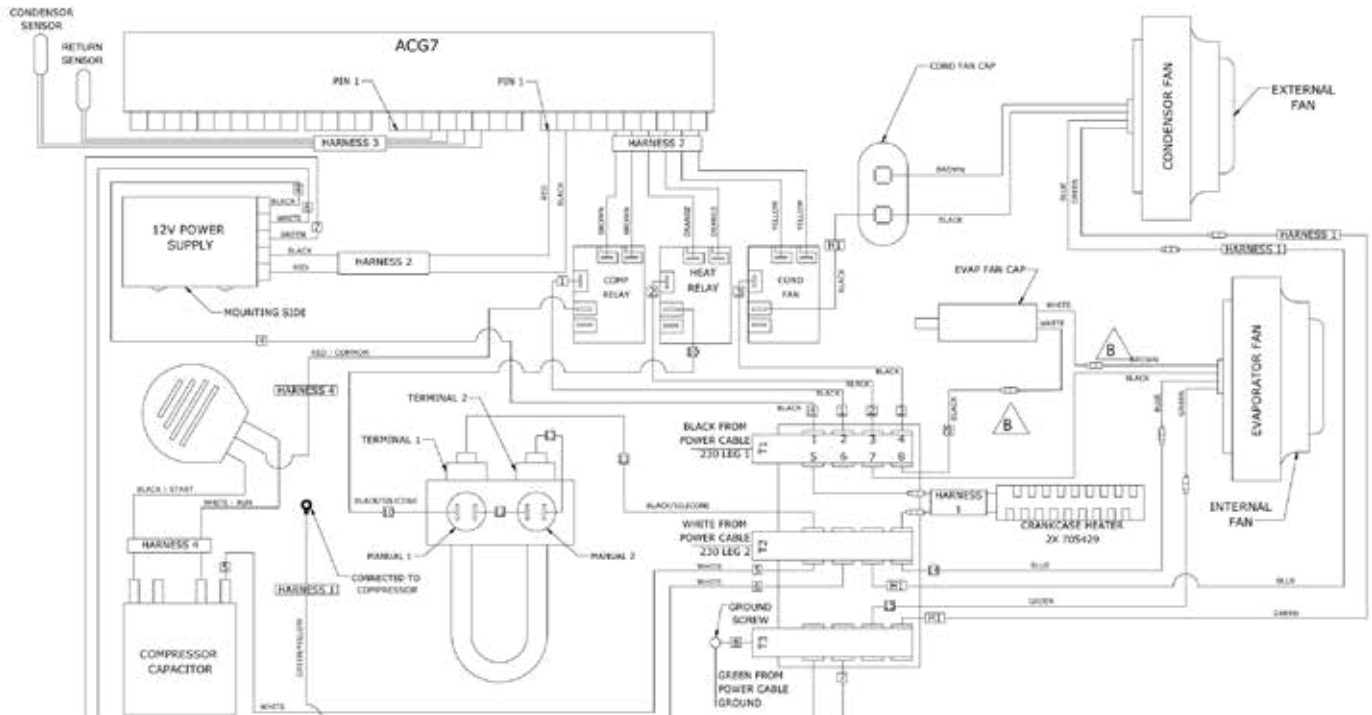

48 VDC

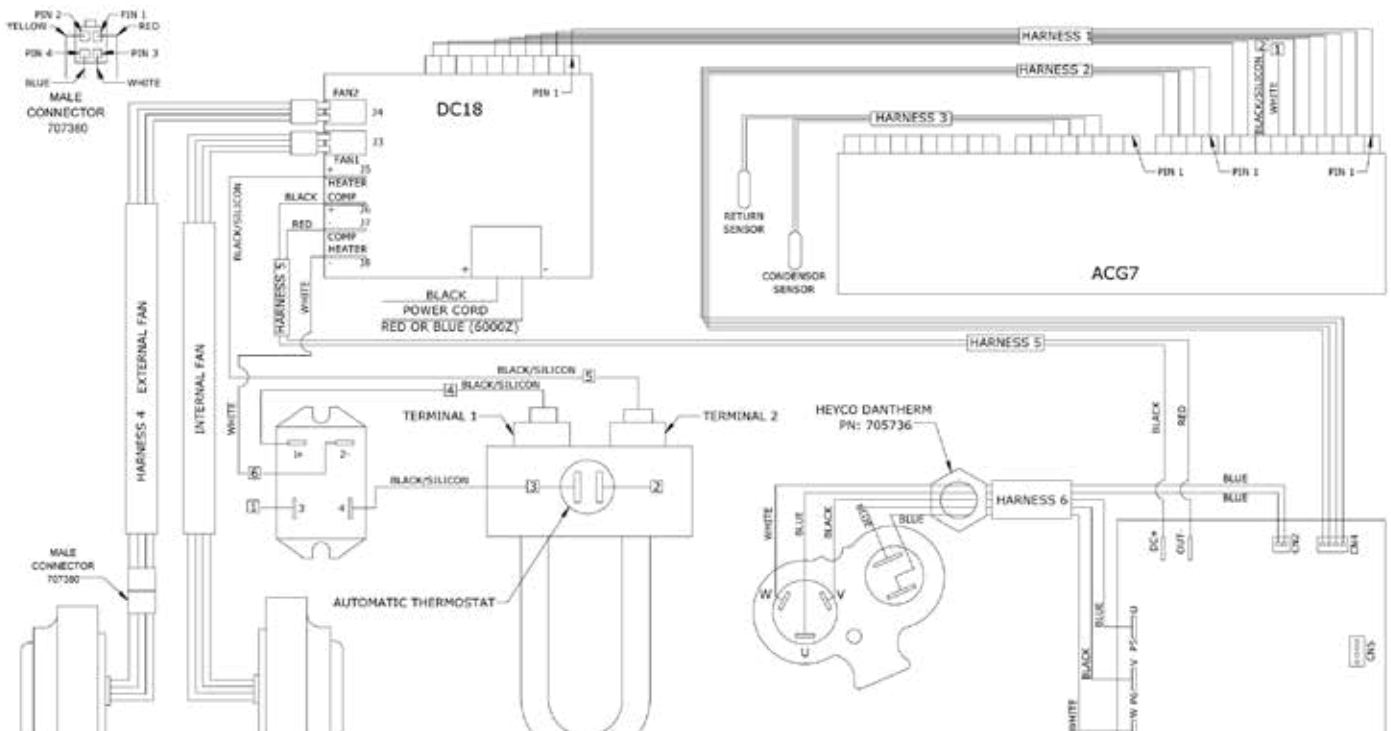

PrecisionAir® 2000

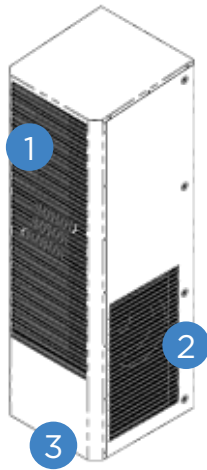

OUTDOOR VIEW	
This illustrates the unit's outdoor view.	
PART	DESCRIPTION
1	Condenser Air Outlet
2	Condenser Air Inlet
3	Removable Front Cover

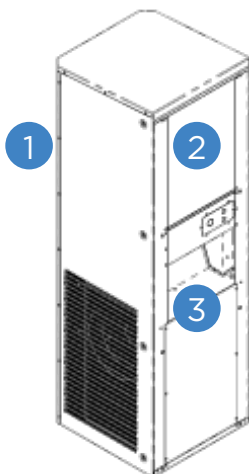

INDOOR VIEW	
This illustrates the unit's indoor view.	
PART	DESCRIPTION
1	Internal Intelligent Thermal Controller
2	Evaporator Return
3	Evaporator Outlet

PrecisionAir® 2000



DRAINAGE	
Optional Drain line is available for routing condensate away from unit if necessary	
PART	DESCRIPTION
1	Condensate Hose

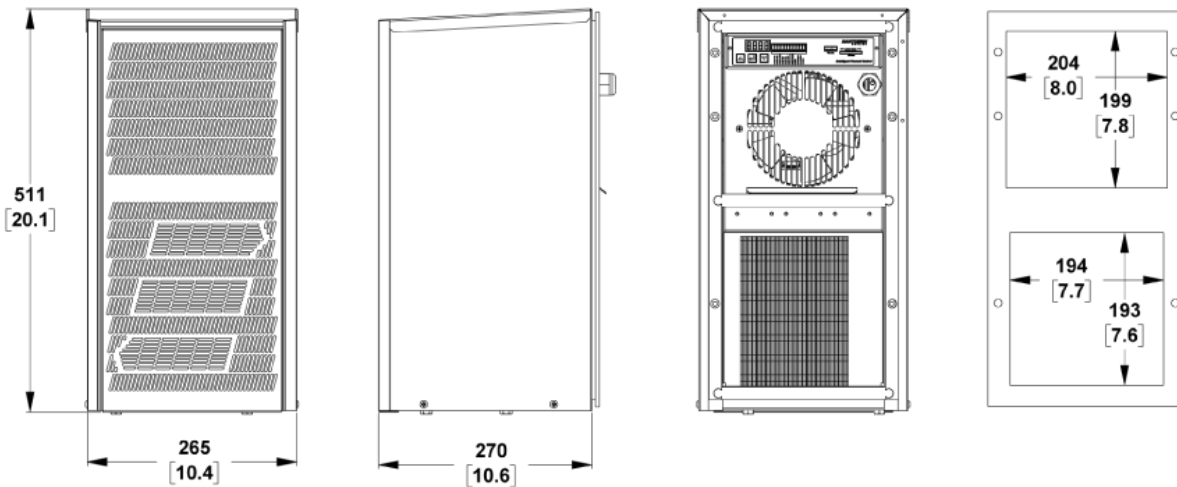

- NOTES:**
- 1) UNITS = MM [IN]
 - 2) STEP FILES AVAILABLE UPON REQUEST

PrecisionAir® 2000

TECHNICAL DATA

These units are designed for high reliability and electrical efficiency.

- Reciprocating Compressor with High Efficiency
- Axial Fans
- Compact Condenser and Evaporator

	UNITS		
MODEL NUMBER	--	PA-2-115	PA-2-230
MOUNTING TYPE	--	Outdoor, NEMA 3R	
UNIT DIMENSIONS [HxWxD]	Inches [mm]	20.25x10.4x10.6 [514.35x264.16x269.24]	
WEIGHT	Lbs [kg]	55 [25]	
COOLING CAPACITY 131°F INTERNAL / 131°F AMBIENT	BTU/h [W]	2,480 [726]	
COOLING CAPACITY 95°F INTERNAL / 95°F AMBIENT	BTU/h [W]	2,160 [629]	
INTERNAL AIRFLOW	CFM [m³/h]	100 [170]	
EXTERNAL AIRFLOW	CFM [m³/h]	100 [170]	
REFRIGERANT/AMOUNT	Type [g]	R134a [210]	
OPERATIONAL TEMPERATURE RANGE	°F [°C]	-40 to 131 [-40 to 55]	
NOISE 1.5M DISTANCE	dB	64	
HEATER	Watts	500	
INPUT VOLTAGE /FREQUENCY	Volts/Hz	115/230 VAC 50/60 Hz	
POWER CONSUMPTION	Amps	8.0	4.0
APPROVALS	--	SA10718 (UL)	
CONSTRUCTION	--	Galvanized Steel, Stainless Optional Textured Powder Coat, Color Options Available	

PrecisionAir® 4000

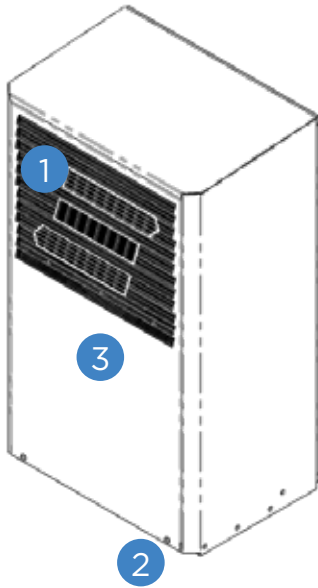

OUTDOOR VIEW	
This illustrates the unit's outdoor view.	
PART	DESCRIPTION
1	Condenser Air Outlet
2	Condenser Air Inlet
3	Removable Front Cover

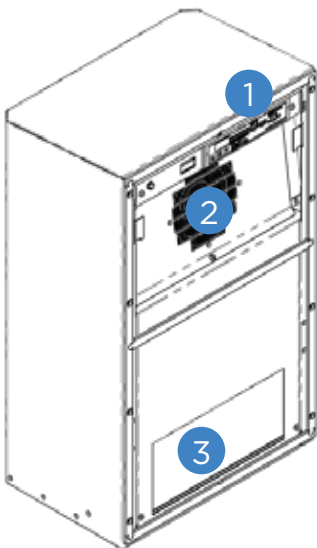

INDOOR VIEW	
This illustrates the unit's indoor view.	
PART	DESCRIPTION
1	Internal Intelligent Thermal Controller
2	Evaporator Return and Fan Guard
3	Evaporator Outlet

PrecisionAir® 4000

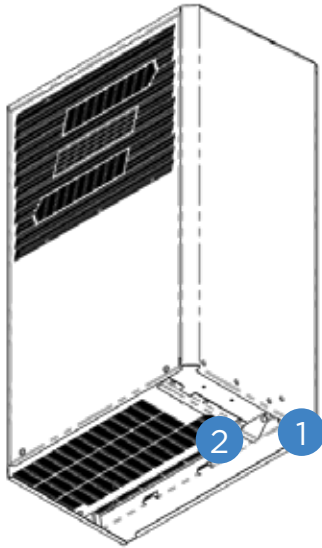

DRAINAGE	
Optional Drain line is available for routing condensate away from unit if necessary	
PART	DESCRIPTION
1	Filter Support Bracket
2	Condensate Drain

FILTERS

The external air inlet in the bottom of the unit, has a cutout pattern of 1/8" by 3/4". This will extensively reduce the risk of leaves or bugs, in the air inlet for condenser cooling.

The slide track in the bottom of the outside part of the enclosure enables the user to slide in replacement filters, that can be purchased as an accessory

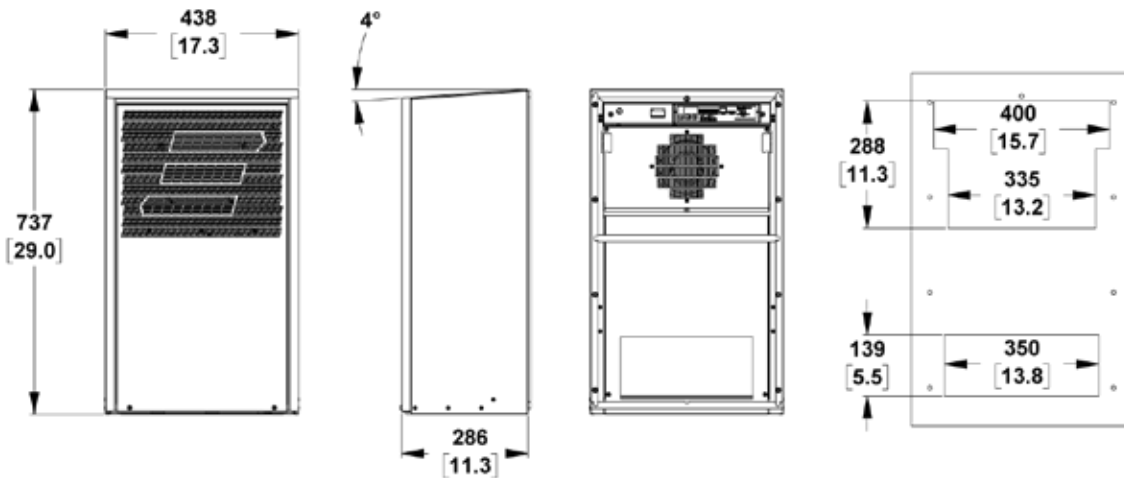

- NOTES:
 1) UNITS = MM [IN]
 2) STEP FILES AVAILABLE UPON REQUEST

PrecisionAir® 4000

TECHNICAL DATA

These units are designed for high reliability and electrical efficiency.

- Reciprocating Compressor with High Efficiency
- Axial Fans
- Compact Condenser and Evaporator

	UNITS				
MODEL NUMBER	--	PA-4-115	PA-4-230	PA-4-460/3	PA-4-48
MOUNTING TYPE	--	Outdoor, NEMA 3R			
UNIT DIMENSIONS [HxWxD]	Inches [mm]	29.0x17.3x11.3 [737x439x286]			
WEIGHT	Lbs [kg]	75 [34]			90 [41]
COOLING CAPACITY 131°F INTERNAL / 131°F AMBIENT	BTU/h [W]	4,270 [1,250]			4,200 [1,230]
COOLING CAPACITY 95°F INTERNAL / 95°F AMBIENT	BTU/h [W]	4235 [1,240]			4000 [1,170]
INTERNAL AIRFLOW	CFM [m³/h]	247 [420]			
EXTERNAL AIRFLOW	CFM [m³/h]	247 [420]			
REFRIGERANT/AMOUNT	Type [g]	R134a [210]			
OPERATIONAL TEMPERATURE RANGE	°F [°C]	-40 to 131 [-40 to 55]			
NOISE 1.5M DISTANCE	dB	<62			<65
HEATER	Watts	1,000			500
INPUT VOLTAGE /FREQUENCY	Volts/Hz	115 VAC 60 Hz	230 VAC 50/60 Hz	460 VAC 50/60 Hz	48 VDC +15%/-20%
POWER CONSUMPTION	Amps	8.9	5.8	2.3	12.0
APPROVALS	--	4010388 (ETL)			SA10718 (UL)
CONSTRUCTION	--	Galvanized Steel, Stainless Optional Textured Powder Coat, Color Options Available			

PrecisionAir® 6000

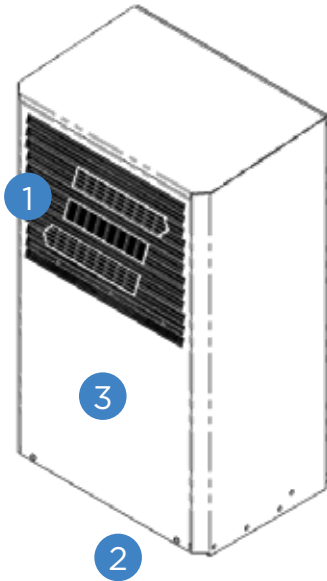

OUTDOOR VIEW	
This illustrates the unit's outdoor view.	
PART	DESCRIPTION
1	Condenser Air Outlet
2	Condenser Air Inlet
3	Removable Front Cover

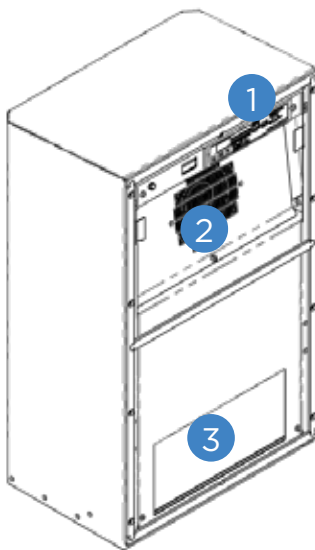

INDOOR VIEW	
This illustrates the unit's indoor view.	
PART	DESCRIPTION
1	Internal Intelligent Thermal Controller
2	Evaporator Return and Fan Guard
3	Evaporator Outlet

PrecisionAir® 6000

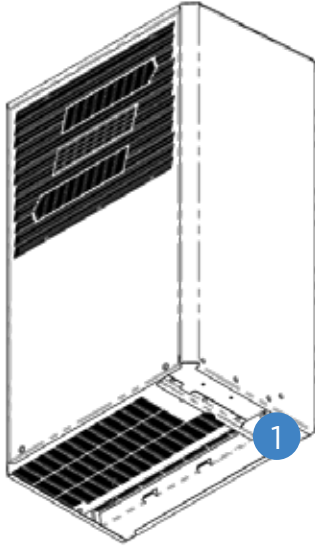

DRAINAGE	
Optional Drain line is available for routing condensate away from unit if necessary	
PART	DESCRIPTION
1	Filter Support Bracket

FILTERS

The external air inlet in the bottom of the unit, has a cutout pattern of 1/8" by 3/4". This will extensively reduce the risk of leaves or bugs, in the air inlet for condenser cooling.

The slide track in the bottom of the outside part of the enclosure enables the user to slide in replacement filters, that can be purchased as an accessory

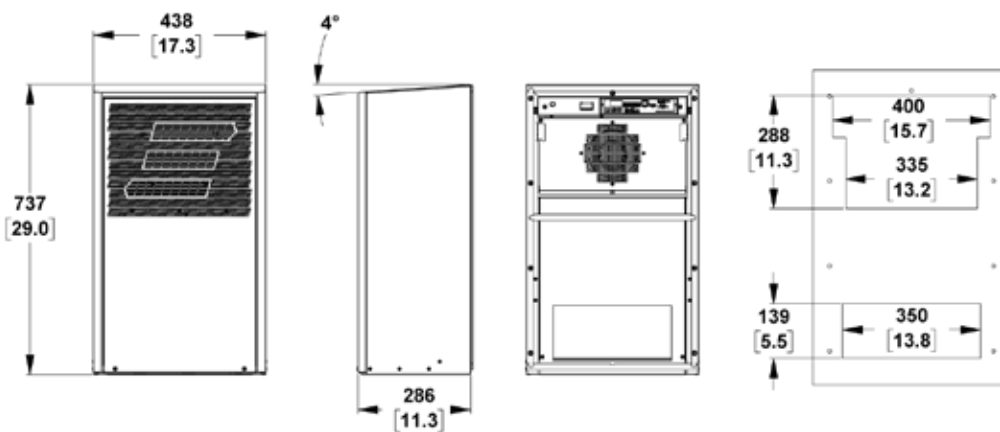

- NOTES:
 1) UNITS = MM [IN]
 2) STEP FILES AVAILABLE UPON REQUEST

PrecisionAir® 6000

TECHNICAL DATA

These units are designed for high reliability and electrical efficiency.

- Reciprocating Compressor with High Efficiency
- Axial Fans
- Compact Condenser and Evaporator

	UNITS				
MODEL NUMBER	--	PA-6-115	PA-6-230	PA-6-460/3	PA-6-48
MOUNTING TYPE	--	Outdoor, NEMA 3R			
UNIT DIMENSIONS [HxWxD]	Inches [mm]	29.0x17.3x11.3 [737x439x286]			
WEIGHT	Lbs [kg]	80 [36]			95 [43]
COOLING CAPACITY 131°F INTERNAL / 131°F AMBIENT	BTU/h [W]	6,000 [1,750]			
COOLING CAPACITY 95°F INTERNAL / 95°F AMBIENT	BTU/h [W]	6,170 [1,806]			
INTERNAL AIRFLOW	CFM [m³/h]	247 [420]			
EXTERNAL AIRFLOW	CFM [m³/h]	247 [420]			
REFRIGERANT	Type [g]	R134a [500]			
OPERATIONAL TEMPERATURE RANGE	°F [°C]	-40 to 131 [-40 to 55]			
NOISE 1.5M DISTANCE	dB	<65			
HEATER	Watts	1,000			500
INPUT VOLTAGE /FREQUENCY	Volts/Hz	115 VAC 60 Hz	230 VAC 50/60 Hz	460 VAC 50/60 Hz	48 VDC +15%/-20%
POWER CONSUMPTION	Amps	10.0	7.0	3.0	16.0
APPROVALS	--	4010388 (ETL)			SA10718 (UL)
CONSTRUCTION	--	Galvanized Steel, Stainless Optional Textured Powder Coat, Color Options Available			

PrecisionAir® 10000, 12000, 14000

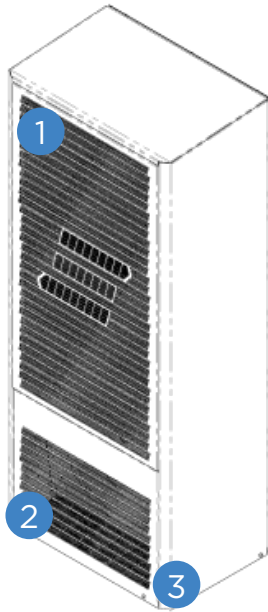

OUTDOOR VIEW	
This illustrates the unit's outdoor view.	
PART	DESCRIPTION
1	Condenser Air Outlet
2	Condenser Air Inlet
3	Removable Front Cover

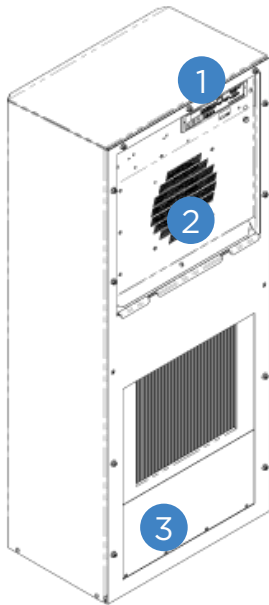

INDOOR VIEW	
This illustrates the unit's indoor view.	
PART	DESCRIPTION
1	Internal Intelligent Thermal Controller
2	Evaporator Return and Fan Guard
3	Evaporator Outlet

PrecisionAir® 10000, 12000, 14000

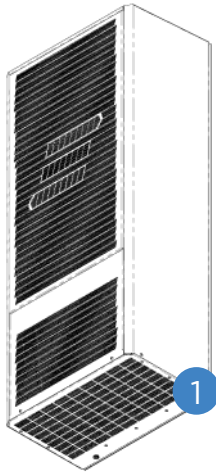

DRAINAGE	
Optional Drain line is available for routing condensate away from unit if necessary	
PART	DESCRIPTION
1	Filter Support Bracket

FILTERS

The external air inlet in the bottom of the unit, has a cutout pattern of 1/8" by 3/4". This will extensively reduce the risk of leaves or bugs, in the air inlet for condenser cooling.

The slide track in the bottom of the outside part of the enclosure enables the user to slide in replacement filters, that can be purchased as an accessory

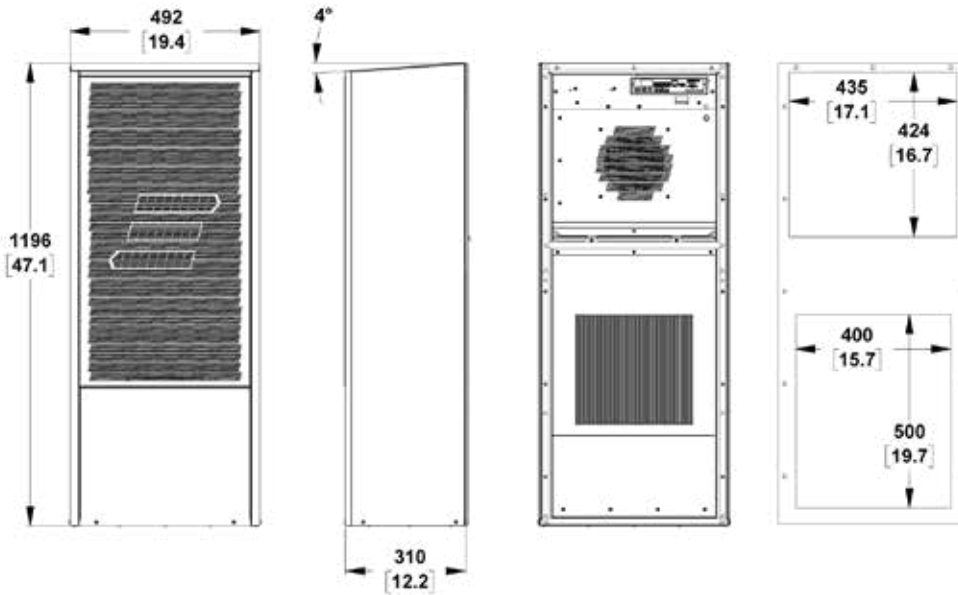

- NOTES:
 1) UNITS = MM [IN]
 2) STEP FILES AVAILABLE UPON REQUEST

PrecisionAir® 10000, 12000, 14000

TECHNICAL DATA

These units are designed for high reliability and electrical efficiency.

- Reciprocating Compressor with High Efficiency
- Axial Fans
- Compact Condensor and Evaporator

	UNITS					
MODEL NUMBER	--	PA-10-230	PA-10-48	PA-12-230	PA-12-48	PA-14-48
MOUNTING TYPE	--	Outdoor, NEMA 3R				
UNIT DIMENSIONS [HxWxD]	Inches [mm]	47.3x19.3x12.2 [1201x490x309]				
WEIGHT	Lbs [kg]	115 [52]				
COOLING CAPACITY 131°F INTERNAL / 131°F AMBIENT	BTU/h [W]	10,700 [3,133]		11,300 [3,000]		14,000 [4,100]
COOLING CAPACITY 95°F INTERNAL / 95°F AMBIENT	BTU/h [W]	10,170 [2,977]		10,300 [3,000]		12,100 [3,545]
INTERNAL AIRFLOW	CFM [m³/h]	210 to 450 [765]				
EXTERNAL AIRFLOW	CFM [m³/h]	400 to 710 [1,205]				
REFRIGERANT/AMOUNT	Type [g]	R134a [500]				
OPERATIONAL TEMPERATURE RANGE	°F [°C]	-40 to 131 [-40 to 55]				
NOISE 1.5M DISTANCE	dB	60 to 65				
HEATER	Watts	2,000	500	2,000	500	
INPUT VOLTAGE /FREQUENCY	Volts/Hz	208/230 VAC 50/60 Hz	48 VDC, +20%/-15%	208/230 VAC 50/60 Hz	48 VDC, +20%/-15%	
POWER CONSUMPTION	Amps	11.0	29.0	11.0	29.0	27.0
APPROVALS	--	SA10718 (UL)				
CONSTRUCTION	--	Galvanized Steel, Stainless Optional Textured Powder Coat, Color Options Available				

PrecisionAir® 14000 Mid Mount

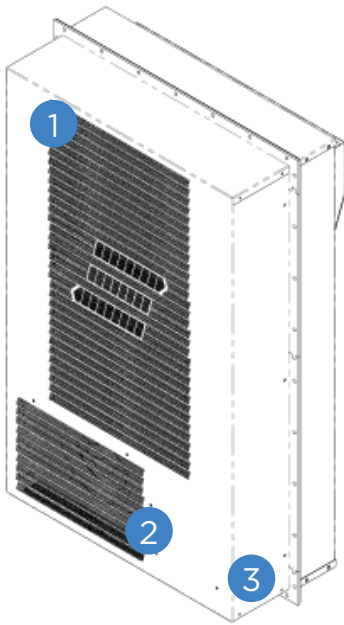

OUTDOOR VIEW	
This illustrates the unit's outdoor view.	
PART	DESCRIPTION
1	Condenser Air Outlet
2	Condenser Air Inlet
3	Removable Front Cover

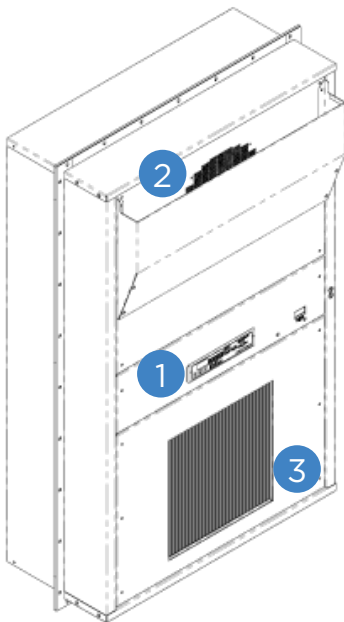

INDOOR VIEW	
This illustrates the unit's indoor view.	
PART	DESCRIPTION
1	Internal Intelligent Thermal Controller
2	Evaporator Return and Fan Guard
3	Evaporator Outlet

PrecisionAir® 14000 Mid Mount

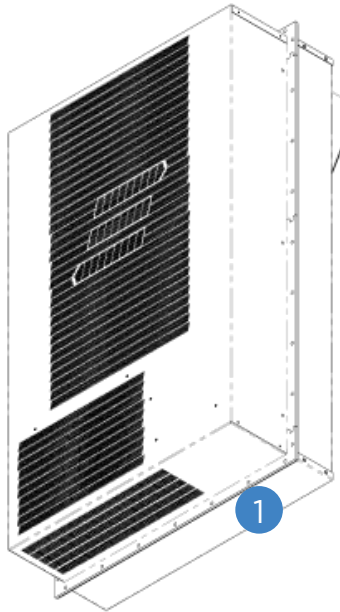

DRAINAGE

Optional Drain line is available for routing condensate away from unit if necessary

PART	DESCRIPTION
1	Filter Support Bracket

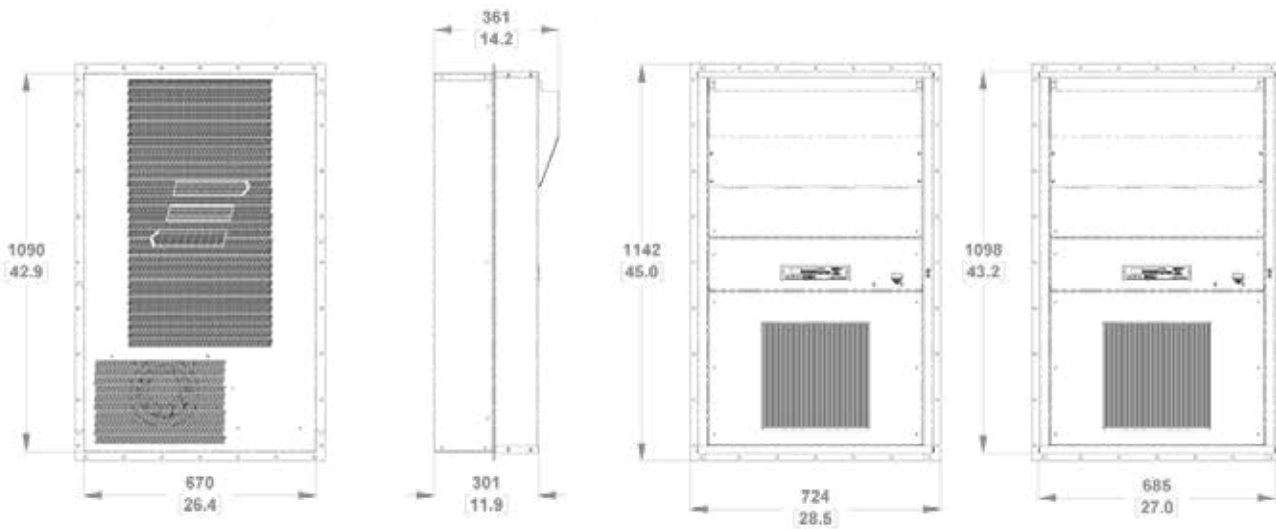

NOTES:
 1) UNITS = MM [IN]
 2) STEP FILES AVAILABLE UPON REQUEST

PrecisionAir® 14000 Mid Mount

TECHNICAL DATA

These units are designed for high reliability and electrical efficiency.

- Reciprocating Compressor with High Efficiency
- Axial Fans
- Compact Condensor and Evaporator

	UNITS	
MODEL NUMBER	--	PA-14-48-MM
MOUNTING TYPE	--	Outdoor, NEMA3R
UNIT DIMENSIONS [HxWxD]	Inches [mm]	42.9x26.3x11.1 [1089x668x282]
WEIGHT	Lbs [kg]	115 [52]
COOLING CAPACITY 131°F INTERNAL / 131°F AMBIENT	BTU/h [W]	14,000 [4,100]
COOLING CAPACITY 95°F INTERNAL / 95°F AMBIENT	BTU/h [W]	12,100 [3,545]
INTERNAL AIRFLOW	CFM [m³/h]	210 to 450 [765]
EXTERNAL AIRFLOW	CFM [m³/h]	400 to 710 [1,205]
REFRIGERANT/AMOUNT	Type [g]	R134a [500]
OPERATIONAL TEMPERATURE RANGE	°F [°C]	-40 to 131 [-40 to 55]
NOISE 1.5M DISTANCE	dB	60 to 65
HEATER	Watts	500
INPUT VOLTAGE /FREQUENCY	Volts/Hz	48 VDC, +20%/-15%
POWER CONSUMPTION	Amps	27.0
APPROVALS	--	SA10718 (UL)
CONSTRUCTION	--	Galvanized Steel, Stainless Optional Textured Powder Coat, Color Options Available

PrecisionAir® 20000



OUTDOOR VIEW	
This illustrates the unit's outdoor view.	
PART	DESCRIPTION
1	Condenser Air Outlet
2	Condenser Air Inlet
3	Removable Front Cover

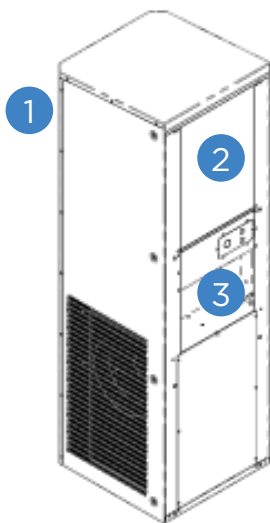

INDOOR VIEW	
This illustrates the unit's indoor view.	
PART	DESCRIPTION
1	Internal Intelligent Thermal Controller
2	Evaporator Return
3	Evaporator Outlet

PrecisionAir® 20000



DRAINAGE	
Optional Drain line is available for routing condensate away from unit if necessary	
PART	DESCRIPTION
1	Filter Support Bracket

FILTERS

The external air inlet in the bottom of the unit, has a cutout pattern of 1/8" by 3/4". This will extensively reduce the risk of leaves or bugs, in the air inlet for condenser cooling.

The slide track in the bottom of the outside part of the enclosure enables the user to slide in replacement filters, that can be purchased as an accessory

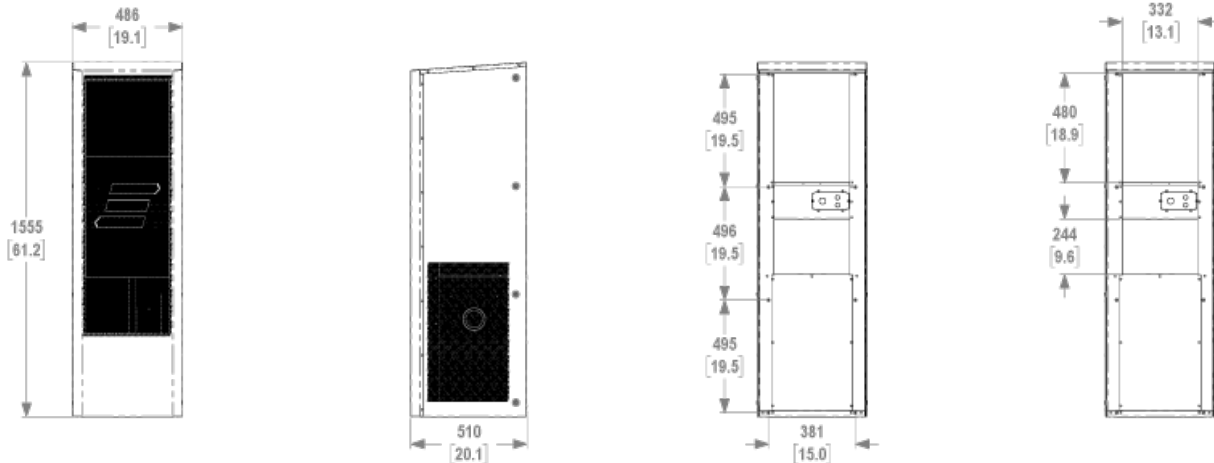

NOTES:

- 1) UNITS = MM [IN]
- 2) STEP FILES AVAILABLE UPON REQUEST

PrecisionAir® 20000

TECHNICAL DATA

These units are designed for high reliability and electrical efficiency.

- Reciprocating Compressor with High Efficiency
- Axial Fans
- Compact Condensor and Evaporator

	UNITS	
MODEL NUMBER	--	PA-20-230
MOUNTING TYPE	--	Outdoor, NEMA 3R
UNIT DIMENSIONS [HxWxD]	Inches [mm]	61x19x20 [1549x483x508]
WEIGHT	Lbs [kg]	200 [91]
COOLING CAPACITY 131°F INTERNAL / 131°F AMBIENT	BTU/h [W]	20,400 [6,030]
COOLING CAPACITY 95°F INTERNAL / 95°F AMBIENT	BTU/h [W]	19,800 [5,800]
INTERNAL AIRFLOW	CFM [m³/h]	1,250 [2,120]
EXTERNAL AIRFLOW	CFM [m³/h]	1,250 [2,120]
REFRIGERANT/AMOUNT	Type [g]	R134a [500]
OPERATIONAL TEMPERATURE RANGE	°F [°C]	-40 to 131 [-40 to 55]
NOISE 1.5M DISTANCE	dB	60 to 65
HEATER	Watts	2,000
INPUT VOLTAGE /FREQUENCY	Volts/Hz	208/230 VAC 50/60 Hz
POWER CONSUMPTION	Amps	15.0
APPROVALS	--	SA10718 (UL)
CONSTRUCTION	--	Galvanized Steel, Stainless Optional Textured Powder Coat, Color Options Available

PrecisionAir® 24/28000

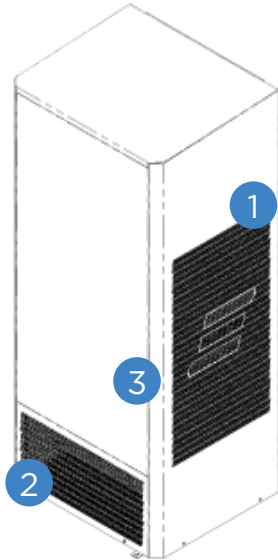

OUTDOOR VIEW	
This illustrates the unit's outdoor view.	
PART	DESCRIPTION
1	Condenser Air Outlet
2	Condenser Air Inlet
3	Removable Front Cover

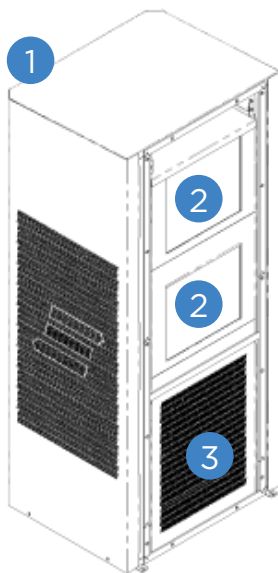

INDOOR VIEW	
This illustrates the unit's indoor view.	
PART	DESCRIPTION
1	Internal Intelligent Thermal Controller
2	Evaporator Return
3	Evaporator Outlet

PrecisionAir® 24/28000

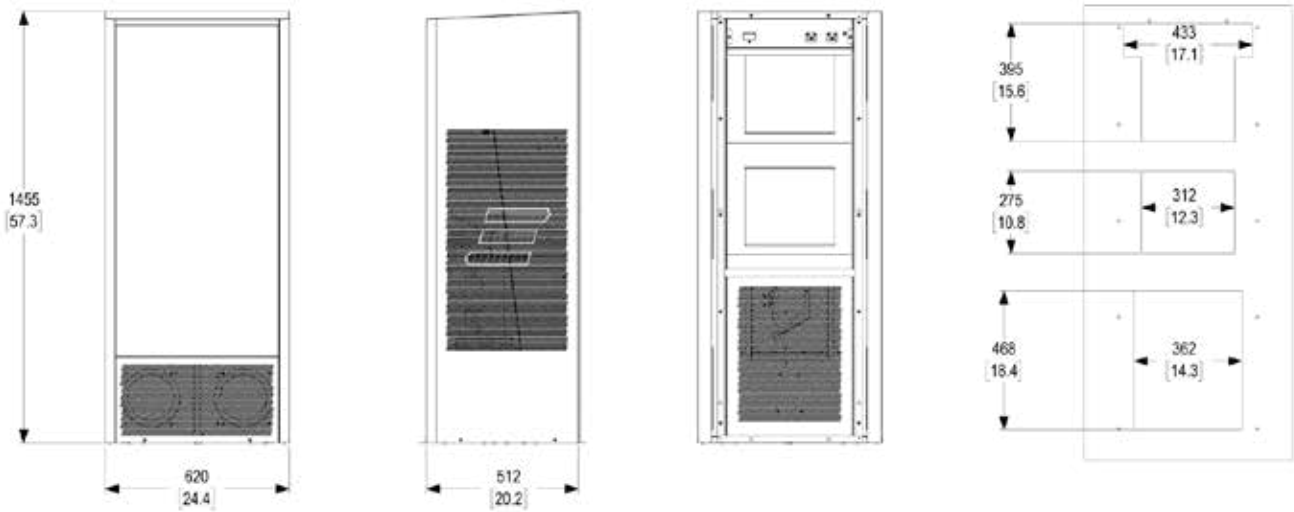

NOTES:

- 1) UNITS = MM [IN]
- 2) STEP FILES AVAILABLE UPON REQUEST

PrecisionAir® 24/28000

TECHNICAL DATA

These units are designed for high reliability and electrical efficiency.

- Reciprocating Compressor with High Efficiency
- Axial Fans
- Compact Condensor and Evaporator

	UNITS			
MODEL NUMBER	--	PA-24-230	PA-24-48	PA-28-48
MOUNTING TYPE	--	Outdoor, NEMA 3R		
UNIT DIMENSIONS [HxWxD]	Inches [mm]	59x24.3x20.2 [1499x617x513]		
WEIGHT	Lbs [kg]	230 [104]		
COOLING CAPACITY 131°F INTERNAL / 131°F AMBIENT	BTU/h [W]	24,000 [7,000]	28,000 [8,200]	
COOLING CAPACITY 95°F INTERNAL / 95°F AMBIENT	BTU/h [W]	22,000 [6,400]	26,000 [7,600]	
INTERNAL AIRFLOW	CFM [m ³ /h]	800 [1,360]		
EXTERNAL AIRFLOW	CFM [m ³ /h]	1,400 [2,380]		
REFRIGERANT/AMOUNT	Type [g]	R134a [1,200]		
OPERATIONAL TEMPERATURE RANGE	°F [°C]	-40 to 131 [-40 to 55]		
NOISE 1.5M DISTANCE	dB	65		
HEATER	Watts	2,000	1,000	
INPUT VOLTAGE/FREQUENCY	Volts/Hz	208/230 VAC 50-60 Hz	48 VDC +15%/-20%	48 VDC +15%/-20%
POWER CONSUMPTION	Amps	20.0	60.0	
APPROVALS	--	SA10718 (UL)		
CONSTRUCTION	--	Galvanized Steel, Stainless Optional Textured Powder Coat, Color Options Available		

PREVENTATIVE MAINTENANCE

Preventive maintenance must be completed in order to:

- Continue operation in specified range
- Avoid malfunctions
- Avoid inefficient operation
- Maximize the unit's lifetime

The factory warranty is only valid if documented preventive maintenance has been carried out, with a time interval of:

- Maximum 6 months when unit is located in normal air quality environment
- Maximum 2 months when unit is located in bad air quality environment

A written log at site is adequate documentation for preventive maintenance.

CAUTION

- Switch off power supply before working on the unit
- Make sure that all work has been performed correctly before switching power back on

The unit must be cleaned according to the recommended preventive maintenance plan.

Tools required:

- Vacuum cleaner or compressed air
- Soft brush
- TORX 20 and 25 Security Driver
- MAC cleaning agent as needed

PHASE	DESCRIPTION
1	Check and clean the outside air inlet grill if needed.
2	Open the units outer cover by removing the two screws in the lower edge of the cover.
3	Vacuum the condenser coil and the visible part of the fan.
4	Vacuum the evaporator coil from the inside of the enclosure.
5	If any of the coils are still dirty, apply AC cleaning agent on coil fins, and after 5 minutes gently rinse off with water, WITHOUT spraying water on any electrical parts.
6	Perform final inspection according to the list in the next section.

INSPECTION

The unit must be inspected before it is reassembled and put back into service.

Please follow the steps below:

PHASE	DESCRIPTION
1	Are the fans clean and free of any corrosion?
2	Are the coolant pipes free of obstructions, damage, corrosion and show no obvious signs of leakage?
3	Are the coils clean and undamaged?
4	Are all fan blades free of any obstructions, cracks or missing blades?
5	When manually rotating the fans, do the fans rotate freely, without vibrations and noise?
6	Is all wiring and insulation undamaged?
7	Are all connector secured properly and in good condition?
8	Inspect the drain hose (if any) for damage or obstruction.
9	Are there any alarms visible on the controller?

TEST COOLING CIRCUIT

The cooling circuit is designed for long durability, and is based only on a few components. Any testing of the circuit should be conducted, only if, a relevant problem has arisen. Open the unit's outside cover, by removing the two screws in the lower part.

Locate the service valve, connect a pressure gauge, and check that the pressure is aligned with the present temperature. Due to critical refrigerant changes, low volume refrigeration hoses with low loss fittings should be used when accessing the refrigeration system. Care should be taken to minimize any amount of lost refrigerant.

SPARE PARTS AND ACCESSORIES

A number of spare parts, replacement parts and accessories are available from Dantherm Cooling. Please contact technical support for more information at:

tech.support@danthermcooling.com

WARRANTY:

DANTHERM COOLING, INC., HEAT EXCHANGERS AND AIR CONDITIONING UNITS HAVE LIMITED WARRANTY.

DANTHERM COOLING, INC. (“DANTHERM”) limited warranty extends to the original purchaser only of any DANTHERM heat exchanger and air conditioning unit, and to no other person or entity. DANTHERM warrants that such DANTHERM products will be free from defects in materials and workmanship in normal use for a period of twelve (12) months from the date of the original purchase. Should any part of your DANTHERM product fail because of a manufacturing defect within such twelve (12) month period, DANTHERM terms are set out below.

IMPORTANT

- Using Dantherm nominated service contractors-warranty on product continues
- Using Dantherm non-approved service contractors – warranty on product becomes void.
- Warranty period starts from date of shipment – warranty of replacement parts shall only apply for the remainder of the warranty period of the original product.

Any transportation, related service labor, diagnosis calls, filters, driers, and refrigerant are not included.

In the event all related service labor is performed by DANTHERM nominated service contractors, the replacement part shall be warranted by DANTHERM for the remainder of the warranty period for the original product.

This warranty does not cover damages or repairs caused by improper installation, misuse of the product, negligent servicing, improper applications, unauthorized modifications, improper electrical supply, failure to follow manufacturer’s instructions and rating plate information, accidents, natural disasters, damage in transportation, lack of normal preventive maintenance, or other events beyond DANTHERM’s control.

This warranty is also subject to the following operating conditions:

- 1) Voltage variation not greater than 10%,
- 2) Frequency variation not greater than 3Hz from nameplate rating
- 3) Cooling load is not greater than product label under rated conditions
- 4) Unit is not restarted for a period of five minutes after accidental or intentional shut-off
- 5) Operation is not subject to abnormal conditions or customer, user misapplication
- 6) Customer or user does not modify, abuse, or neglect the product
- 7) Refrigerant specified on nameplate is only refrigerant used
- 8) Customer or user complies with all other installation, maintenance, and operating instructions. Cost of repair or replacement of consumable parts is not covered under the terms of this warranty.

THIS WARRANTY CONSTITUTES THE EXCLUSIVE REMEDY OF ANY PURCHASER OF A DANTHERM HEAT EXCHANGER, AIR CONDITIONING UNIT AND IS IN LIEU OF ALL OTHER WARRANTIES. THIS ALSO INCLUDES, WITHOUT LIMITATION, ANY IMPLIED WARRANTIES OF MERCHANTABILITY, FITNESS FOR USE, OR FOR A PARTICULAR PURPOSE. IN NO EVENT SHALL ANY IMPLIED WARRANTIES OF MERCHANTABILITY, FITNESS FOR USE, OR FOR A PARTICULAR PURPOSE EXCEED THE TERMS OF THE APPLICABLE WARRANTY STATED ABOVE, AND DANTHERM SHALL HAVE NO OTHER OBLIGATION OR LIABILITY, EXPRESS OR IMPLIED. IN NO EVENT SHALL DANTHERM BE LIABLE FOR ANY INCIDENTAL OR CONSEQUENTIAL DAMAGES. THIS WARRANTY GIVES YOU SPECIFIC LEGAL RIGHTS, AND YOU MAY ALSO HAVE OTHER RIGHTS WHICH VARY FROM STATE TO STATE. SOME STATES DO NOT ALLOW LIMITATIONS OR EXCLUSIONS, SO THE ABOVE LIMITATIONS AND EXCLUSIONS MAY NOT APPLY TO YOU.

RETURN MATERIAL AUTHORIZATION PROCEDURE

In the unlikely event of unit failure, the following return procedure shall be adopted:

- All product returns require a Return Material Authorization number regardless of reason.
- The customer is required to contact the Quality Department at Dantherm Cooling, Inc. in Spartanburg, SC at +1-864-595-9800 to obtain an RMA number.

The following information must be provided prior to a RMA number being issued:

- Dantherm Cooling, Inc. part number(s) of product to be returned
- Dantherm Cooling, Inc. serial number(s) of product to be returned.
- Number of units requested to be returned. Reason for return.
- Contact name, phone and fax number. Date of product receipt.
- Invoice number and purchase order number covering the unit(s).

The customer is responsible for suitably packaging the unit(s) securely, ideally in the original packaging, marking all cartons with the RMA number and shipping them prepaid to the designated site specified by Dantherm Cooling, Inc.

IN NO EVENT SHALL DANTHERM COOLING, INC. ACCEPT ANY SHIPMENT WHICH DOES NOT COMPLY WITH THE ABOVE PROCEDURES.

REMOVE THE CONDENSATE HOSE AND ADAPTER FROM THE BOTTOM OF THE UNITS PRIOR TO DISMANTLING THE AIR CONDITIONER AND RESTING IT ON THE GROUND.

DECLARATION OF CONFORMITY

Dantherm Cooling Inc., Spartanburg, SC hereby declare that the units PrecisionAir 50/60Hz are in conformity with the following directives:

UL 60335-1 Fifth Edition

UL 60335-2-40 First Edition

CAN/CSA-C22.2 No. 60335-1-11 First Edition

CAN/CSA-C22.2 No. 60335-2-40. . . First Edition

Spartanburg, SC – September.20.2018

Recycling: The unit should be recycled according to national rules and procedures to protect the environment. Please consult your local authorities for further information.

DANTHERM COOLING

DANTHERMCOOLING.COM

TECH.SUPPORT@DANTHERMCOOLING.COM | 864-595-9800

671 SPRINGFIELD ROAD | SPARTANBURG, SOUTH CAROLINA 29303