

DANTHERM

COOLING

PrecisionAir® WS & SL

Product User Manual



INTRODUCTION

This is the service manual for Dantherm PrecisionAir WS units. Please see the table of contents below for further information about the sections of this manual.

TARGET GROUP

The target group for this service manual are the technicians who install and maintain the PrecisionAir WS series units.

COPYRIGHT

Copying of this service manual, or part of it, is forbidden without prior written permission from Dantherm Cooling Inc.

RESERVATIONS

Dantherm reserves the right to make changes and improvements to the product and the service manual at any time without prior notice or obligation.

TABLE OF CONTENTS

UNPACKING SAFETY WARNING	3
MODEL IDENTIFICATION.....	4-5
WS	4
SL	5
MODEL OVERVIEW	6-7
WS	6
SL	7
PRODUCT DESCRIPTION	8-10
INSTALLATION.....	11-13
OPERATIONS AND CONTROLLER	14-18
WS UNIT OVERVIEW	19-28
WS 2T	19-20
WS 3T	21-22
WS 3.5T.....	23-24
WS 4T	25-26
WS 5T	27-28
SL UNIT OVERVIEW	29-31
SL 4T/5T	29-31
MAINTENANCE SPARE PARTS	32-33
WARRANTY	34
RMA DECLARATION OF CONFORMITY.	35

UNPACKING, HANDLING, AND INSPECTION

Thank you for purchasing a Dantherm PrecisionAir WS unit. Please carefully review all handling and installation instructions.

- HVAC systems should be maintained in an upright position at all times to prevent refrigerator oil migration.
- While unpacking, the unit should be inspected for any damage that may have occurred during shipment.
- Damage to the unit or packaging should be immediately addressed with the shipping carrier.
- Do not attempt to operate or repair the unit if it appears to be damaged.
- Any damage as a result from mishandling is not covered under Dantherm Cooling's standard warranty.

GENERAL SAFETY

Certain parts of electrical systems are inevitably live or have a high operating temperature. Observe caution at all times.

- Failure to observe these conditions and installation instructions can cause injury and damage.
- The system is to be installed and maintained only by trained and qualified personnel.
- Do not apply power until all ground connections have been made.
- The unit is fitted with pressed and folded metal parts, which could have sheared metal edges. Be cautious handling the unit, especially when working in poorly accessible places.
- Check that no tools, test equipment, torches etc. have been left in or on the equipment on completion of work.
- Ensure the cover(s) and all mounting hardware is firmly secured before leaving installation.
- All cable and connectors must conform to UL standards.

- Most models are UL recognized and tested to UL484. It will comply where necessary within the safety requirements as defined in UL484.
- When servicing the unit, do not remove the cover(s) for 5 minutes after switching the unit off to allow pipe work (compressor discharge) to cool.

WARNINGS

INTRODUCTION: This installation manual and the product uses various displays and labels to ensure safe use. Ignoring these displays and labels and incorrectly using the product could have results as classified below. Please read the following warning symbol information before reading the rest of this section, and be sure to strictly observe all instructions.

GENERAL PRECAUTION: This appliance is not intended for use by persons (including children) with reduced physical, sensory or mental capabilities, or lack of experience and knowledge, unless they have been given supervision or instruction concerning use of the appliance by a person responsible for their safety. Children should be supervised to ensure that they do not play with the appliance. If the power cord is damaged, it must be replaced by the manufacturer, a service agent, or a similar qualified person in order to avoid a hazard.

⚠ WARNING: Not following these instructions could result in death or serious injury.

⚠ CAUTION: Not following these instructions could result in injury or property damage.

⚠ This symbol will show for something that should NOT be done.

Project safety is your responsibility! Follow the instructions in this manual regarding the installation method and installation orientation. Not following these instructions could result in injury, death, or damage to equipment. All work should be performed by qualified personnel using safe work practices. All proper protective equipment should be used. PPE required for this installation may include, but is not limited to: Safety glasses | Hard hat | Safety shoe | Hearing protection | Cut resistant gloves | Face shield | Proper work attire (long sleeve shirt and long pants)

MODEL IDENTIFICATION

PA-WS-AC-60-S-B-05-S-H-G-04

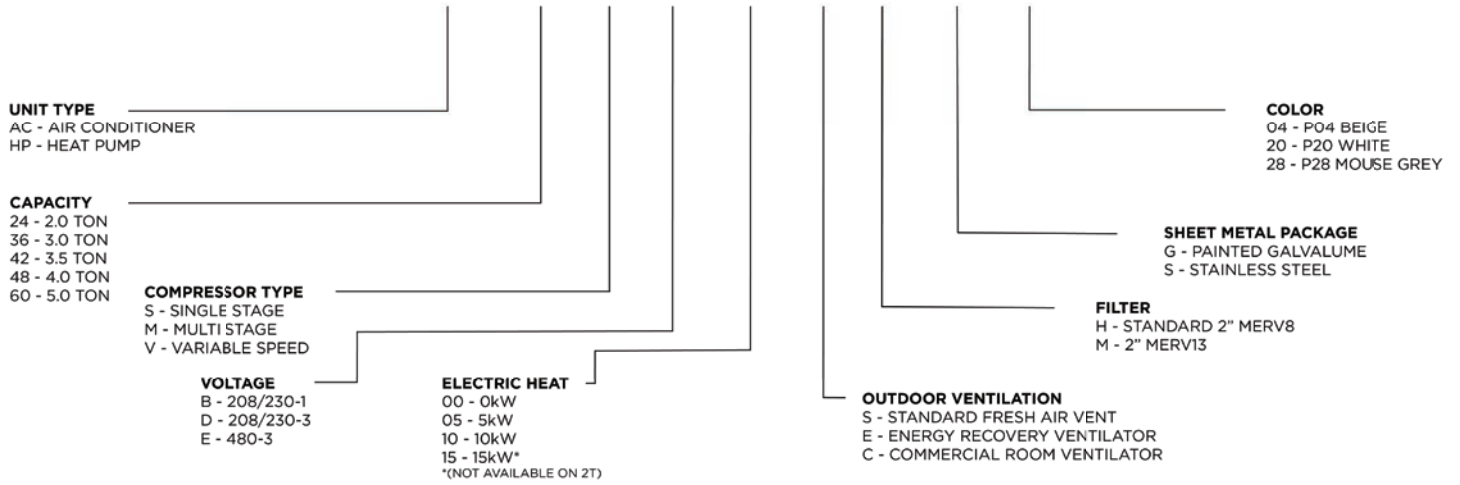

Color Options



04 - P04 Beige



20 - P20 White



28 - P28 Mouse Grey

MODEL IDENTIFICATION

PA-SL-AC-60-S-B-05-S-H-G-04

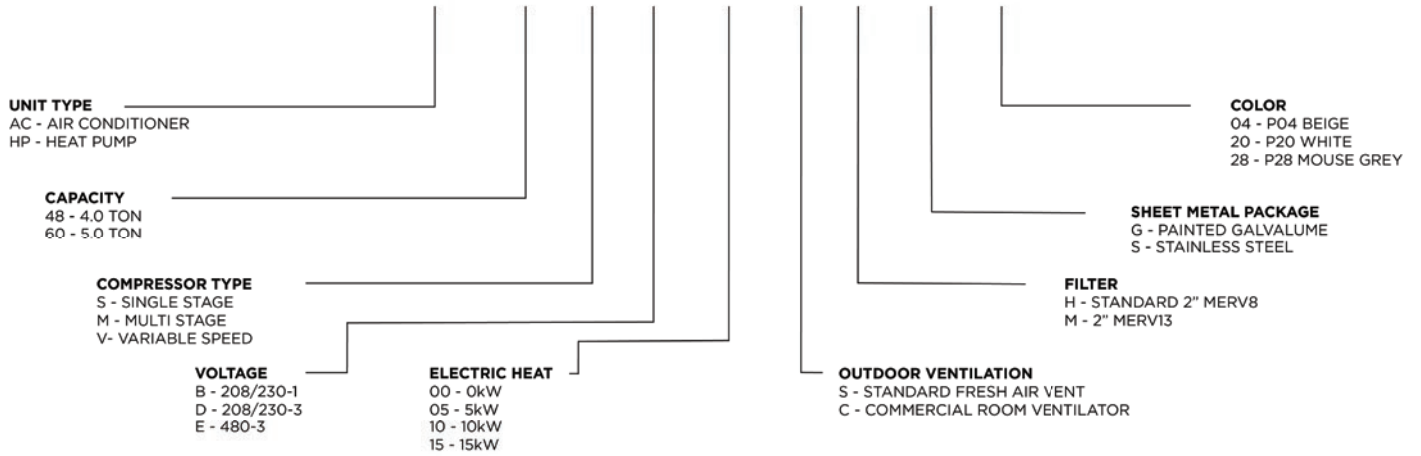

Color Options

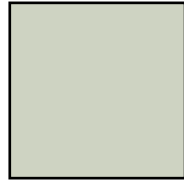

04 - P04 Beige



20 - P20 White



28 - P28 Mouse Grey

MODEL OVERVIEW				
PA	ENCLOSURE SIZE INCHES [MM] H X W X D	COOLING CAPACITY/BTU	HEATER POWER/WATT	VOLTAGE/FREQUENCY
PA-WS-24	75x35x17.6 [1905X889X447]	24,000 [7.5kW]	5/10/15kW Options	208/230 VAC, 1Ø 60hz
PA-WS-36	75x40x17.8 [1905X1016X452]	36,000 [11kW]	5/10/15kW Options	208/230 VAC, 1Ø 60hz 208/230 VAC, 3Ø 60hz 480 VAC, 3Ø 60hz
PA-WS-42/48/60	92x43.9x24.5 [2337X1115X622]	42,000 - 60,000 [12kW - 18kW]	5/10/15kW Options	208/230 VAC, 3Ø 60hz 480 VAC, 3Ø 60hz

MODEL OVERVIEW				
PA	ENCLOSURE SIZE INCHES [MM] H X W X D	COOLING CAPACITY/BTU	HEATER POWER/WATT	VOLTAGE/FREQUENCY
PA-SL-AC/HP-48	87.8x22.9x25.8 [2230X582X655]	48,000 [14kW]	5/10/15kW Options	208/230 VAC, 1Ø 60hz 208/230 VAC, 3Ø 60hz 480 VAC, 3Ø 60hz
PA-SL-AC/HP-60	87.8x22.9x25.8 [2230X582X655]	60,000 [20kW]	5/10/15kW Options	208/230 VAC, 1Ø 60hz 208/230 VAC, 3Ø 60hz 480 VAC, 3Ø 60hz

PROUCT DESCRIPTION

The PrecisionAir WS and SL series are designed to control the internal temperature of an enclosure by removing dissipated heat from inside the structure, and is designed to maintain accurate temperatures for electronic equipment.

IMPORTANT

Dantherm Cooling Inc. recommends that the cooling system should run continuously.

FUNCTIONALITY

The illustration below shows the airflow of the air conditioner. The two air flows (internal/external) operate separately. External air is only used to cool down the condenser which dissipates the heat absorbed by the indoor evaporator. The air flows are not mixed.

INTERNAL AIR FLOW

Warm, internal air is drawn into the unit by the internal evaporator fan. The air is then pushed through the evaporator, and then released into the enclosure through the evaporator opening.

EXTERNAL AIR FLOW

Cold, external air is drawn into the unit by the condenser fan, and then routed through the condenser, where it is cooled. After passing through the condenser, the air is returned to the external environment.

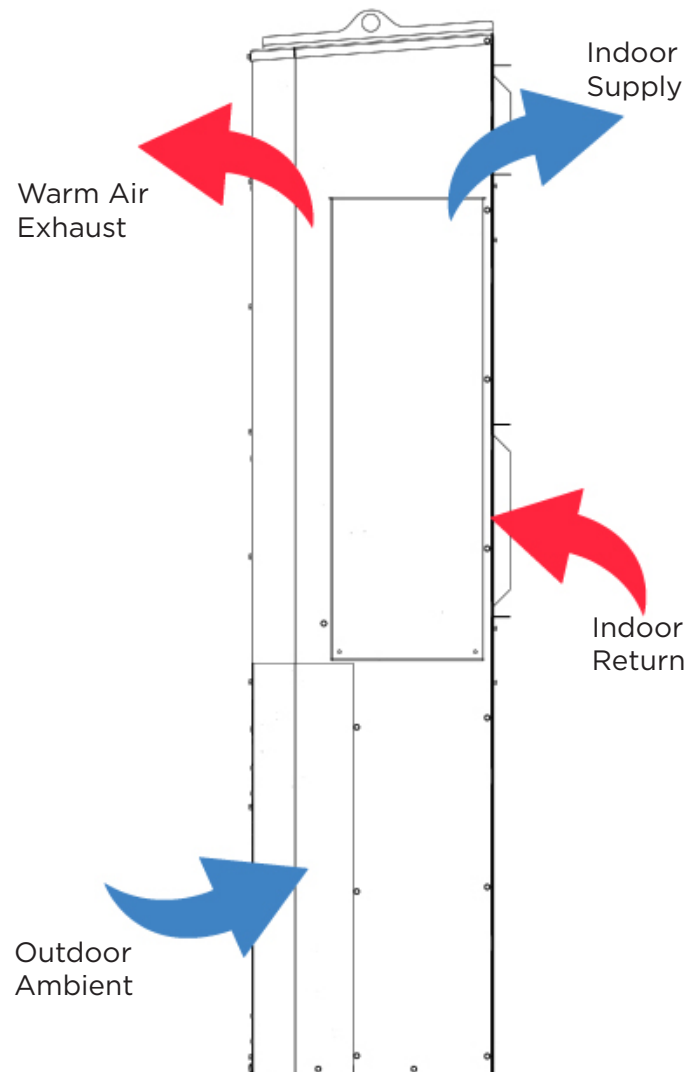

PRODUCT DESCRIPTION

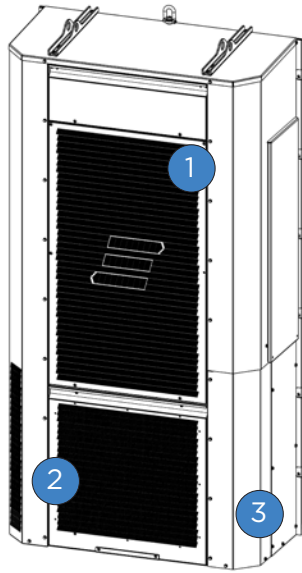

OUTDOOR VIEW

This illustrates the unit's outdoor view.

PART	DESCRIPTION
1	Condenser Air Outlet
2	Condenser Air Inlet
3	Removable Front Cover

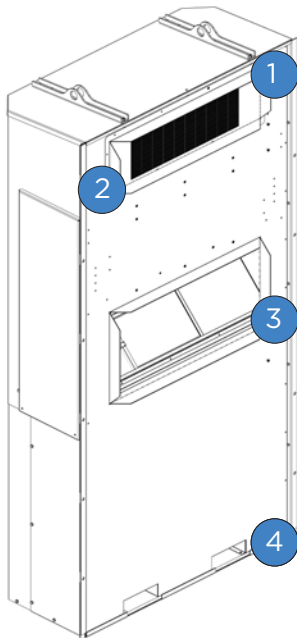

INDOOR VIEW

This illustrates the unit's indoor view.

PART	DESCRIPTION
1	Evaporator outlet
2	Evaporator fan guard
3	Evaporator return
4	Bottom Fork Lift Pockets

PRODUCT DESCRIPTION

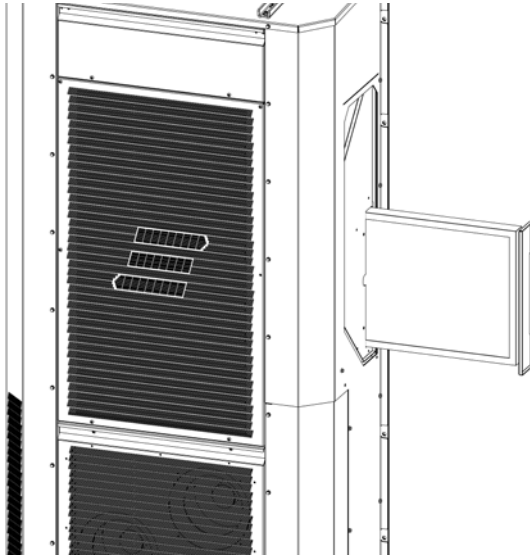
**FILTERS**

Filter access is made easily from either the left or right sides of the unit. Additional filters may be purchased from Dantherm as an accessory.

INSTALLATION

Please strictly observe the following:

Special skills are required to install Dantherm products. Non-qualified personnel should not attempt any of the actions shown in this installation guide. Dantherm shall not be responsible for improper installation or any accidents, damages, or injury resulting from improper installation.

This unit is designed to be mounted outdoor, flush to the wall. Any other installation method is not recommended.

⚠ WARNING

Never carry out any installation, maintenance or service, without disconnecting the power supply.

⚠ WARNING

RISK OF ELECTRIC SHOCK. CAN CAUSE INJURY OR DEATH: System contains oversize protective earthing (grounding) terminal which should be properly connected.

INSTALLATION PLACEMENT

Any installation should allow good air flow inside the enclosure. The unit has cold temperature supply in the lower part and return air in the upper part of the unit. Please consider how to achieve the best possible air flow when selecting appropriate placement. Any installation should be finished with a proper Polymer sealing outside to prevent any water intrusion.

Lift the unit into the cutouts and place it on the hanging brackets, if applicable. Place the bolt from the inside and secure them one by one, taking great care that no damage is done to the unit or enclosure due to the small variation in enclosure structure. The maximum torque is 120in.-lbs with a recommended assembly torque of 75in.-lbs.

The method of fixing stated is not to depend on the use of adhesives since they are not considered to be a reliable fixing means. The dimensions of the space necessary for correct installation of the appliance including the minimum permissible distances to adjacent structures.

The unit must be mounted a minimum 3ft (1m) off the ground so that the outside top of the unit is off the ground/floor by a minimum of 6.5ft (2m). The bottom of the air discharge opening must be a minimum of 6ft (1.8m) off the ground/floor.

After fastening all of the bolts, the unit should be sealed on the outside, top and side junctions towards the enclosure.

DUCTED VS. FREE FLOW INSTALLATIONS

No exposed combustibles are to be within the immediate area/duct of the Air Conditioner Supply. Metal sleeves are to be used. Failure to do so could result in fire damage, injury or death.

ELECTRICAL REQUIREMENTS

Please incorporate the following imperative requirements when installing the electrical connections:

ELECTRICAL CONNECTIONS

After successful unit installation, the electrical connections will be completed, after following the below requirements:

⚠ WARNING

1. The power and/or additional connections need to be routed, secured and connected to appropriate sources. The PrecisionAir unit is delivered with knockouts for field connections.
2. Connect the PrecisionAir units ground terminal to enclosure grounding.
3. All power supply connections are to be secured with an external disconnection device, as well as over current protected.
4. Connect any needed accessories.

⚠ WARNING

Any installation should always be in accordance with national wiring regulations, DC / AC external supply should be protected, with an external disconnecting device that has a contact separation of at least 3 mm. This external DC / AC supply must also be over current protected. These disconnecting devices, must always be labeled, with rated voltage as well as rated current.

- The units earth connections must always be connected to the enclosures ground.
- All cables, in a permanent installation, are imperative to install and secure properly to prevent any damage to equipment and/or humans. Secure all cables with cable ties or appropriate cable fasteners, made for this purpose.

LIFTING HOOKS AND MOUNTING BRACKETS

The unit can be lifted into place by the hanging hooks or by the forklift pockets. The optional mounting bracket should be placed **securely** on the enclosure. The unit can be hung on the mounting bracket.

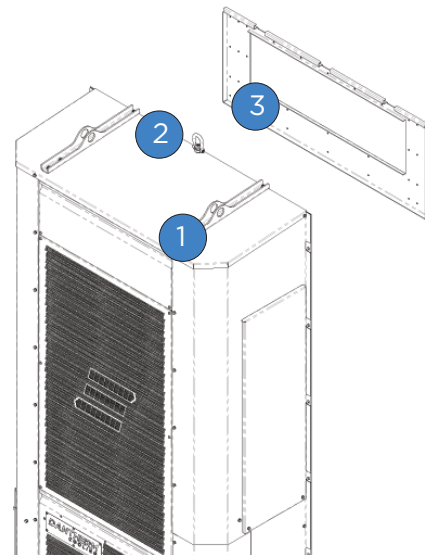

OUTER VIEW	
This illustrates where the hooks and brackets can be found.	
PART	DESCRIPTION
1	Lifting hooks
2	Forklift pockets
3	Optional mounting bracket

KNOCKOUTS AND LOW VOLTAGE CONNECTION

Knockouts are provided in the bottom of the unit for external disconnects, and provided in the back of the unit for the internal wiring. Low voltage connections are through the Wago lever lock connections

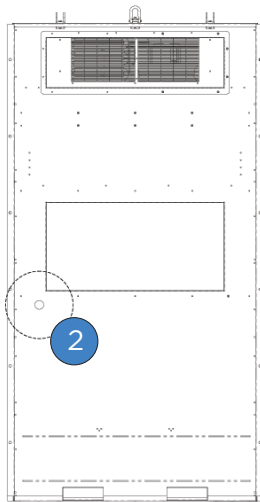
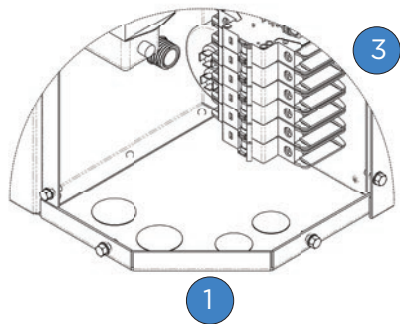

SERVICE

Controls are accessed in the lower right section. Carefully remove the screws to expose the compartment.

The refrigerant charge can be checked through the service ports located behind the access panel in the lower left panel. This allows inspection of the system without removing the fan grill.

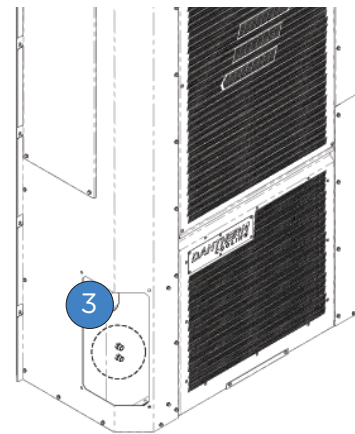
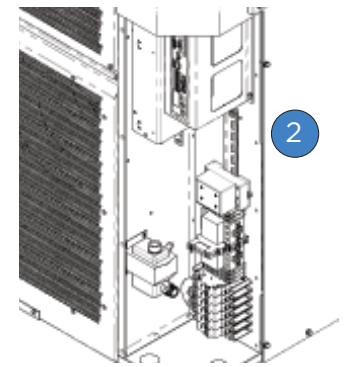
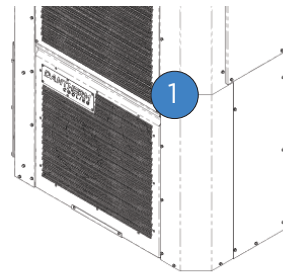

KNOCKOUTS AND LOW VOLTAGE

This illustrates where knockouts are provided and location of low voltage connections.

PART	DESCRIPTION
1	Bottom knockouts for external disconnects
2	Back unit knockouts for internal wiring
3	Low voltage connections

SERVICE ACCESS

This illustrates where service access points are located.

PART	DESCRIPTION
1	Control access cover
2	Control compartment
3	Refrigerant charge location

HEAT PUMP DEFROST CONTROL BOARD

Heat Pumps are equipped with a universal heat pump defrost controller to ensure proper operation including low ambient conditions. The menu can be accessed by pressing the “o” button. The up and down buttons are used to adjust the value of each setting. Factory settings applicable to the WSHP are shown in the table below.

DISPLAY	DESCRIPTION	WSHP SETTING
1	Defrost Enable Temp	35F
2	Termination Temp	70F
3	Defrost Cycle Time*	30 min
4	Short Cycle Delay	0 min
5	Reversing Valve Type**	B
6	Reverse Delay	30 sec
7	Maximum Defrost Time	14 min
8	Aux Heat Lockout Temp	No lockout (OF)
9	Compressor Lockout Temp	No lockout (OF)

* Time the coil temperature is below Defrost Enable Temperature before a defrost trigger.

** Valve energized in heat

COMPRESSOR SHORT CYCLE PROTECTION

Single phase units are equipped with an Emerson SureSwitch contactor. Short Cycle and Brown Out protection reduces stress on the compressor promoting long life. By default, the contactor is set with the “Delay” and “Brown” to “ON”. The short cycle protection ensures that there are at least 3 minutes of off time for the compressor. An LED indicates operation of the SureSwitch.

SURESWITCH LED	CONDITION
SLOW GREEN	Standby
SOLID GREEN	Normal
FAST GREEN	Delay
GREEN / RED	Low Line Voltage
GREEN / YELLOW / RED	Test

Three phase units are equipped with a Littlefuse Protection Relay that disables the system during a fault condition including Reverse Phase, Missing Phase, Voltage Imbalance, Low Voltage and High Voltage. This reduces stress on the compressor promoting long life. An LED indicates operation of the 3 Phase Protection Relay.

3 PHASE LED	CONDITION
SOLID GREEN	Normal
FLASHING GREEN	Delay
STEADY FLASHING RED	Reverse Phase
TWO FLASHING RED	Unbalance / Single Phase
SOLID RED	High / Low Voltage

FAN MOTOR TIME DELAY

Both indoor and outdoor fan motors are equipped with a forced on time delay to help with pressure balancing. This will keep both fan motors running for approximately 1 minute after the compressor shuts down.

DRAINAGE

The air conditioner is provided with a condensate drain attached to a 90 degree elbow. This elbow can be pulled out from the bottom of the unit for connection to a hose to route condensate away from the unit. The condensate drain should be periodically inspected for blockage as part of the maintenance program.

EXTERNAL THERMOSTAT

Standard models allow for integration into a field connected, low voltage thermostat. Connections follow industry standards and are labeled on the inside panel of the unit. Check the thermostat settings correspond to the unit features.

ELECTRONIC CONTROL DESCRIPTION

This section describes key features of the optional ACG7 controller, and how it operates. The optional ACG7 controller is located behind the removable front access panel.

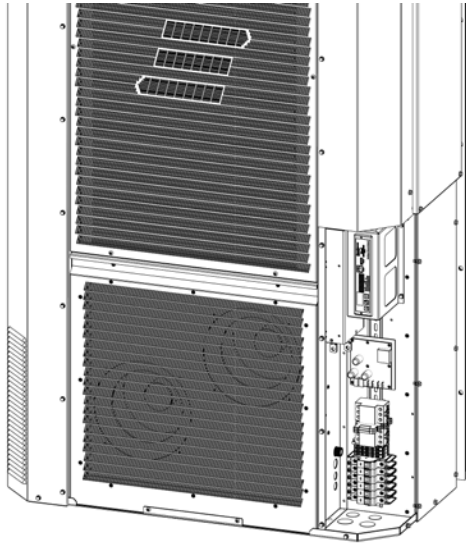

⚠ WARNING

Never carry out any installation, maintenance or service, without disconnecting the power supply.

EMBEDDED CONTROLLER

The built in all in one controller, controls the unit in the most efficient way. Basic parameters can be set via on board control panel, from inside the enclosure. Extended parameter settings, as well as, logging of operation data, is possible through the SD card interface.

CONTROL STRATEGY

The controller regulates the fans heater, and cooling based on desired set points.

- When operating, the evaporator fans will circulate the indoor air continually.
- When temperature in the enclosure is higher than set-point the compressor will start, which initiates cooling.
- The compressor will stop once set-point and hysteresis is achieved.
- A high temperature alarm (when temp is higher than 50° C) will initiate an alarm on the alarm output.
- Low temperature alarm (when temp is lower than 1° C) will initiate an alarm on the alarm output.
- The condenser fan operates only when the actual temperature on the condenser surface requires this operation.

OPERATION PANEL

The below illustrates the operation panel, from inside the enclosure.

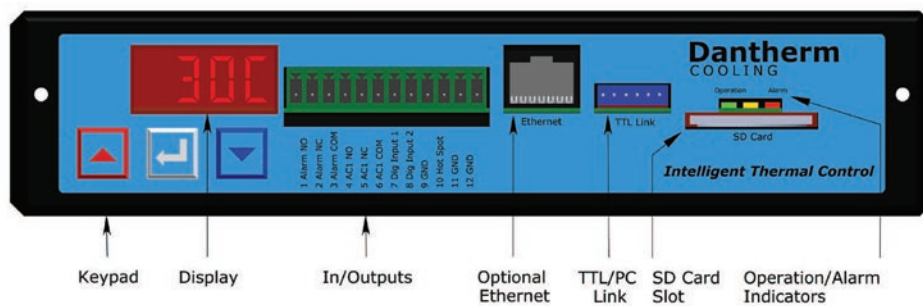

CONNECTIONS

The control board is placed internally alongside the edge of the unit's enclosure. This allows the internal connections to be inserted to the internal board. This reveals the external connections through the cut out in the sheet metal front plate.

CONNECTIONS ILLUSTRATIONS

This illustration shows the external connections to the controller.

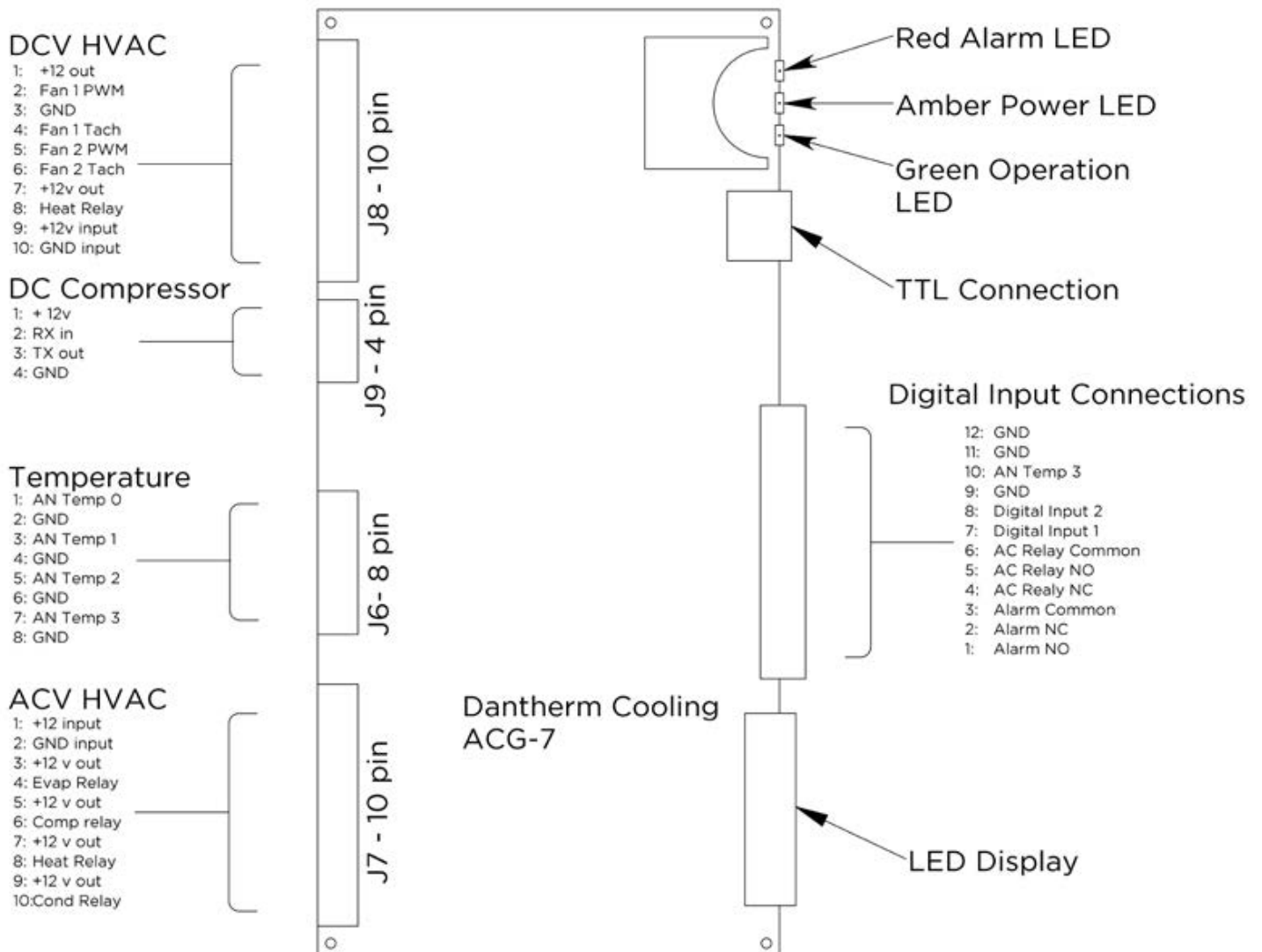

CONNECTIONS

The air conditioner can operate as a standalone cooling system if you connect it to the proper electrical cord and use the operation panel on the front of the controller. For enhanced usage, it is possible to connect an external display with keypad.

CONNECTION	USAGE	SPECIFICATION																																																																																
ALARM 1, 2, 3	This output will toggle open/ close if any operation errors occurs.	Potential Free Max. 42 ACV or 60 DCV. / 500mA Galvanic Isolated (500V)																																																																																
AC 4, 5, 6	This output will toggle lead/lag function of second HVAC. Additional instructions are available.	Potential Free Max. 42 ACV or 60 DCV. / 500mA Galvanic Isolated (500V)																																																																																
DIGITAL INPUT 7, 9	This input can control and overrule some operation parameters. See more in the parameters list.	0/12 DCV Max. 10mA																																																																																
DIGITAL INPUT 8, 9	This input can control and overrule some operation parameters. See more in the parameters list.	0/12 DCV Max. 10mA																																																																																
HOTSPOT SENSOR 9, 10	This is the temperature sensor for placing inside the enclosure. It can be placed in a hotspot zone, if required.	NTC -30 to 85°C (-22 to 185 °F)																																																																																
COOL (Cool)	Press the “up” or “down” key to change the “compressor on” temperature. Pressing “enter” returns to the main display. After 30 seconds of no action, it will revert to the main display.																																																																																	
HEAT (HEAT)	Press the “up” or “down” key to change the “compressor on” temperature. Pressing “enter” returns to the main display. After 30 seconds of no action, it will revert to the main display.																																																																																	
TEST (tEst)	Press the “up” or “down” key to change the “compressor on” temperature. Pressing “enter” returns to the main display. After 4 minutes of no action, it will revert to the main display.																																																																																	
	<table border="1"> <thead> <tr> <th>Step</th> <th>Evap</th> <th>Cond</th> <th>AC</th> <th>Heater</th> <th>DC Fan 1 (evap)</th> <th>DC Fan 2 (cond)</th> <th>DC comp</th> </tr> </thead> <tbody> <tr> <td>0</td> <td>off</td> <td>off</td> <td>off</td> <td>off</td> <td>off</td> <td>off</td> <td>off</td> </tr> <tr> <td>1</td> <td>on</td> <td>off</td> <td>off</td> <td>off</td> <td>off</td> <td>off</td> <td>off</td> </tr> <tr> <td>2</td> <td>on</td> <td>off</td> <td>off</td> <td>off</td> <td>off</td> <td>off</td> <td>off</td> </tr> <tr> <td>3</td> <td>on</td> <td>on</td> <td>on</td> <td>off</td> <td>off</td> <td>off</td> <td>off</td> </tr> <tr> <td>4</td> <td>on</td> <td>on</td> <td>off</td> <td>off</td> <td>off</td> <td>off</td> <td>off</td> </tr> <tr> <td>5</td> <td>on</td> <td>off</td> <td>off</td> <td>on</td> <td>100%</td> <td>off</td> <td>off</td> </tr> <tr> <td>6</td> <td>off</td> <td>off</td> <td>off</td> <td>off</td> <td>100%</td> <td>100%</td> <td>off</td> </tr> <tr> <td>7</td> <td>off</td> <td>off</td> <td>off</td> <td>off</td> <td>100%</td> <td>100%</td> <td>100%</td> </tr> <tr> <td>8</td> <td>off</td> <td>off</td> <td>off</td> <td>off</td> <td>off</td> <td>off</td> <td>off</td> </tr> </tbody> </table>		Step	Evap	Cond	AC	Heater	DC Fan 1 (evap)	DC Fan 2 (cond)	DC comp	0	off	off	off	off	off	off	off	1	on	off	off	off	off	off	off	2	on	off	off	off	off	off	off	3	on	on	on	off	off	off	off	4	on	on	off	off	off	off	off	5	on	off	off	on	100%	off	off	6	off	off	off	off	100%	100%	off	7	off	off	off	off	100%	100%	100%	8	off	off	off	off	off	off	off
	Step	Evap	Cond	AC	Heater	DC Fan 1 (evap)	DC Fan 2 (cond)	DC comp																																																																										
	0	off	off	off	off	off	off	off																																																																										
	1	on	off	off	off	off	off	off																																																																										
	2	on	off	off	off	off	off	off																																																																										
	3	on	on	on	off	off	off	off																																																																										
	4	on	on	off	off	off	off	off																																																																										
	5	on	off	off	on	100%	off	off																																																																										
	6	off	off	off	off	100%	100%	off																																																																										
7	off	off	off	off	100%	100%	100%																																																																											
8	off	off	off	off	off	off	off																																																																											
ERR (Err)	Display the error code if there is an error. If no error is present, this is not shown.																																																																																	
	<table border="1"> <tbody> <tr> <td>5</td> <td>High / Low temp</td> <td>9</td> <td>return sensor</td> </tr> <tr> <td>6</td> <td>dc fan 1</td> <td>10</td> <td>hotspot sensor</td> </tr> <tr> <td>7</td> <td>dc fan 2</td> <td>13</td> <td>condensor sensor</td> </tr> <tr> <td>8</td> <td>dc comp</td> <td>16</td> <td>high pressure</td> </tr> </tbody> </table>		5	High / Low temp	9	return sensor	6	dc fan 1	10	hotspot sensor	7	dc fan 2	13	condensor sensor	8	dc comp	16	high pressure																																																																
	5	High / Low temp	9	return sensor																																																																														
	6	dc fan 1	10	hotspot sensor																																																																														
	7	dc fan 2	13	condensor sensor																																																																														
8	dc comp	16	high pressure																																																																															
UNIT (unit)	Toggle between “C” and “F”. Set points will change on the display accordingly. The TTL display will remain in Celsius. After 30 seconds of no action, it will revert to the main display.																																																																																	

CONNECTIONS	 <p style="text-align: center;"> 1 Alarm NO 2 Alarm NC 3 Alarm COM 4 ACT NO 5 ACT NC 6 ACT COM 7 Dig Input 1 8 Dig Input 2 9 GND 10 Hot Spot 11 GND 12 GND </p> <p>FORM "C" ALARM: Connect to 1 & 3 for "Open" during alarm, "Close" during normal operation. Connect 2 & 3 for "Closed" during alarm, "Open" during normal operation.</p> <p>AC OUTPUT: Connect to 4 & 6 for controlling external air conditioner. See separate document for lead/ lag operation.</p> <p>DIG INPUT 1: When 7 & 9 are connected, until will cool in override mode. See sperate document for lead/ lag operation.</p> <p>DIG INPUT 2: For use with a door switch to interrupt operation of the unit.</p> <p>HOT SPOT SENSOR: Connect Dantherm Cooling sensor to 10 & 11 for remote sensing operation.</p>
SD CARD / DATA LOGGING	<p>An SD card can be inserted into the controller for automatic data logging. The data file will be labeled "log.txt". This is useful for capturing field related issues over time. The card must be a 32GB or smaller, SD or SDHC. Larger sizes and SDXC are not supported. If needed, a heading of the log file ("loghdr.txt") can be obtained by contacting technical support, which assists in identifying the fields.</p>
TTL LINK / ETHERNET	<p>For factory use.</p>

OPERATION

The ACG-7 uses a keypad style that uses operator interface to navigate menus, control operations, and view alarms.

KEY OPERATION

The functionality on the control panel is as follows:

- Left key is step up
- Right key is step down
- Middle key is select

NAVIGATING MENU

Menu structure and navigation. Step up/down to jump through menus, press enter to select the parameter to read or change.

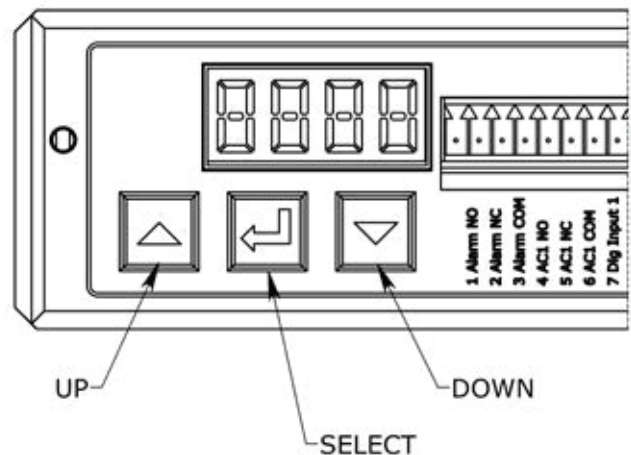

PrecisionAir® WS 2T

Technical Data

	UNITS	
MODEL NUMBER	--	PA-WS-24
MOUNTING TYPE	--	Vertical, Outdoor, NEMA/UL 3R, 4
UNIT DIMENSIONS [HxWxD]	Inches [mm]	75x35x17.6 [1905x889x447]
WEIGHT	Lbs [kg]	325 [148]
COOLING CAPACITY 80°F INTERNAL / 95°F AMBIENT	BTU/h [W]	24,000 [7.5kW]
MAX INTERNAL AIRFLOW @ .5 IN H ₂ O	CFM [m ³ /h]	1,800 [3,060]
MAX EXTERNAL AIRFLOW	CFM [m ³ /h]	1,800 [3,060]
REFRIGERANT	Type	R134a or R513a [GWP=573]
OPERATIONAL TEMPERATURE RANGE	°F [°C]	-40 to 113 [-40 to 45]
NOISE 1.5M DISTANCE	dB	<65
HEATER	kWatts	5/10kW Options
INPUT VOLTAGE /FREQUENCY	Volts/Hz	208/230 VAC, 1Ø 60Hz
COMPRESSOR RLA	Amps	10.7
COMPRESSOR LRA	Amps	72
CONDENSER HP	HP	0.1
EVAPORATOR FAN HP	HP	0.1
COOLING CURRENT MIN	Amps	15
COOLING CURRENT PROTECTION	Amps	20
EER [SP=0.1] / EER2 [SP=0.5]	--	11.0 / 12.0
COP [HEAT PUMP MODE]	--	3.3
APPROVALS	--	UL/Intertek ANSI/AHRI Standard 390-2021
CONSTRUCTION	--	Galvanized & Galvalume Steel, Stainless Steel Optional Textured Powder Coat Standard, Color Options Available

PrecisionAir® WS 3T

Dimensional Drawing

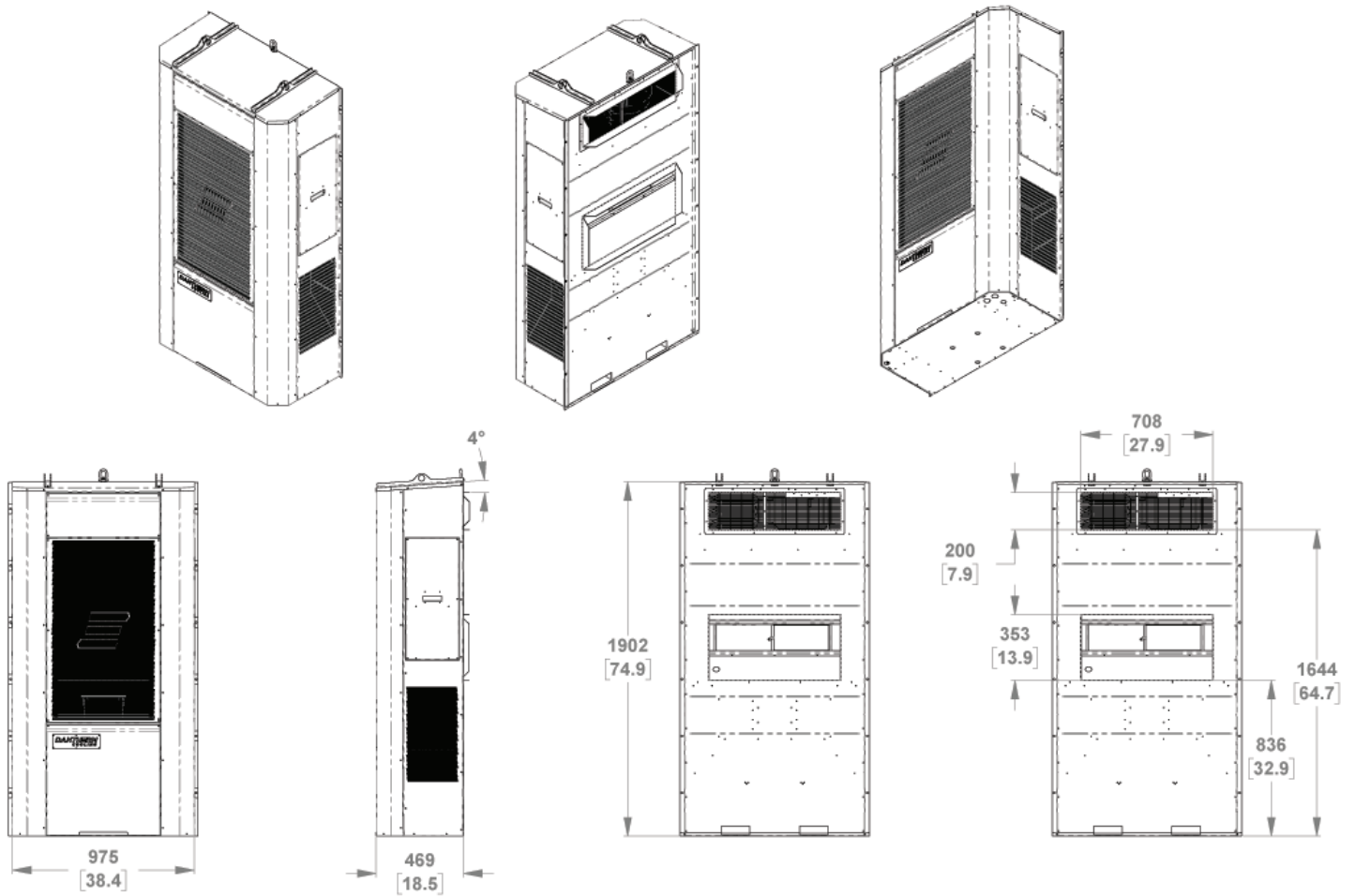

NOTES:

1. UNITS = MM [IN]
2. STEP FILE AVAILABLE UPON REQUEST
3. DO NOT SCALE DRAWING

PrecisionAir® WS 3T

Technical Data

	UNITS			
MODEL NUMBER	--	PA-WS-AC-36, PA-WS-HP-36		
MOUNTING TYPE	--	Vertical, Outdoor, NEMA/UL 3R, 4		
UNIT DIMENSIONS [HxWxD]	Inches [mm]	75x40x17.8 [1905x1016x452]		
WEIGHT	Lbs [kg]	350 [159]		
COOLING CAPACITY 80°F INTERNAL / 95°F AMBIENT	BTU/h [W]	36,000 [11kW]		
MAX INTERNAL AIRFLOW @ .5 IN H ₂ O	CFM [m ³ /h]	1,300 [2,200]		
MAX EXTERNAL AIRFLOW	CFM [m ³ /h]	1,800 [3,060]		
REFRIGERANT	Type	R410a or R454b [GWP=467]		
OPERATIONAL TEMPERATURE RANGE	°F [°C]	-40 to 113 [-40 to 45]		
NOISE 1.5M DISTANCE	dB	<65		
HEATER	kWatts	5/10/15kW Options		
INPUT VOLTAGE /FREQUENCY	Volts/Hz	208/230 VAC, 1Ø 60Hz	208/230 VAC, 3Ø 60Hz	480 VAC, 3Ø 60Hz
COMPRESSOR RLA	Amps	19.8	14.1	6.4
COMPRESSOR LRA	Amps	115	95	45
CONDENSER HP	HP	0.1 (x2)	0.1 (x2)	0.1 (x2)
EVAPORATOR FAN HP	HP	.3	.3	.3
COOLING CURRENT MIN	Amps	25	15	10
COOLING CURRENT PROTECTION	Amps	30	20	15
EER [SP=0.1] / EER2 [SP=0.5]	--	11.0 / 12.0		
COP [HEAT PUMP MODE]	--	3.3		
APPROVALS	--	UL/Intertek ANSI/AHRI Standard 390-2021		
CONSTRUCTION	--	Galvanized & Galvalume Steel, Stainless Steel Optional Textured Powder Coat Standard, Color Options Available		

PrecisionAir® WS 3.5T

Dimensional Drawing

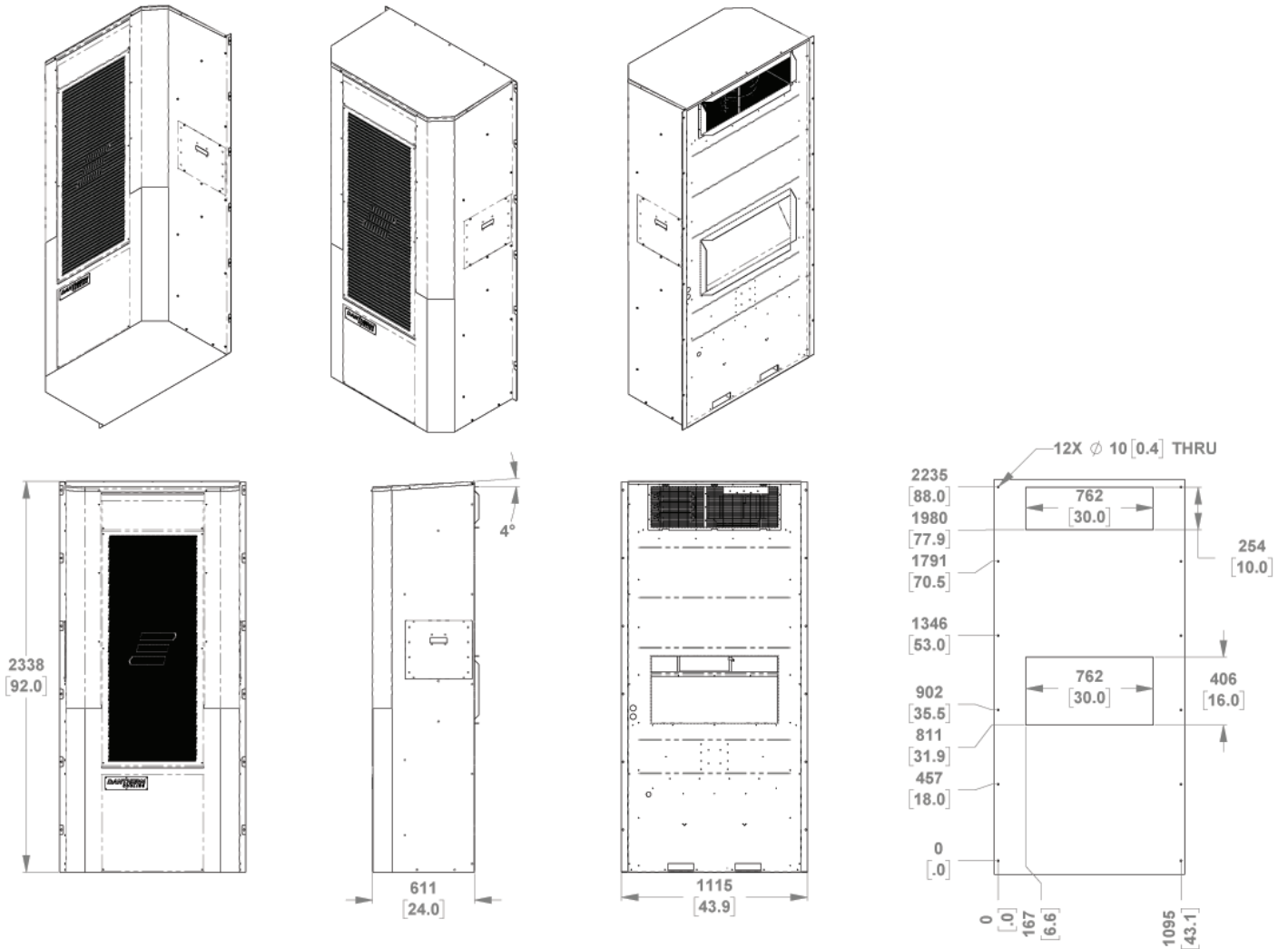

NOTES:

1. UNITS = MM [IN]
2. STEP FILE AVAILABLE UPON REQUEST
3. DO NOT SCALE DRAWING

PrecisionAir® WS 3.5T

Technical Data

	UNITS			
MODEL NUMBER	--	PA-WS-AC-42, PA-WS-HP-42		
MOUNTING TYPE	--	Vertical, Outdoor, NEMA/UL 3R, 4		
UNIT DIMENSIONS [HxWxD]	Inches [mm]	92x43.9x24.5 [2337x1115x622]		
WEIGHT	Lbs [kg]	475 [215.5]		
COOLING CAPACITY 80°F INTERNAL / 95°F AMBIENT	BTU/h [W]	42,000 [14kW]		
MAX INTERNAL AIRFLOW @ .5 IN H ₂ O	CFM [m ³ /h]	1,600 [2,700]		
MAX EXTERNAL AIRFLOW	CFM [m ³ /h]	3,600 [6,100]		
REFRIGERANT	Type	R410a or R454b [GWP=467]		
OPERATIONAL TEMPERATURE RANGE	°F [°C]	-40 to 113 [-40 to 45]		
NOISE 1.5M DISTANCE	dB	<65		
HEATER	kWatts	5/10/15kW Options		
INPUT VOLTAGE /FREQUENCY	Volts/Hz	208/230 VAC, 1Ø 60Hz	208/230 VAC, 3Ø 60Hz	480 VAC, 3Ø 60Hz
COMPRESSOR RLA	Amps	21.1	14.1	6.4
COMPRESSOR LRA	Amps	105	95	45
CONDENSER HP	HP	1.5	1.5	1.5
EVAPORATOR FAN HP	HP	1.3	1.3	1.3
COOLING CURRENT MIN	Amps	35	20	10
COOLING CURRENT PROTECTION	Amps	40	25	15
EER [SP=0.1] / EER2 [SP=0.5]	--	11.0 / 12.0		
COP [HEAT PUMP MODE]	--	3.3		
APPROVALS	--	UL/Intertek ANSI/AHRI Standard 390-2021		
CONSTRUCTION	--	Galvanized & Galvanized Steel, Stainless Steel Optional Textured Powder Coat Standard, Color Options Available		

PrecisionAir® WS 4T

Technical Data

	UNITS			
MODEL NUMBER	--	PA-WS-AC-48, PA-WS-HP-48		
MOUNTING TYPE	--	Vertical, Outdoor, NEMA/UL 3R, 4		
UNIT DIMENSIONS [HxWxD]	Inches [mm]	92x43.9x24.5 [2337x1115x622]		
WEIGHT	Lbs [kg]	475 [215.5]		
COOLING CAPACITY 80°F INTERNAL / 95°F AMBIENT	BTU/h [W]	48,000 [16kW]		
MAX INTERNAL AIRFLOW @ .5 IN H ₂ O	CFM [m ³ /h]	1,800 [3,100]		
MAX EXTERNAL AIRFLOW	CFM [m ³ /h]	3,600 [6,100]		
REFRIGERANT	Type	R410a or R454b [GWP=467]		
OPERATIONAL TEMPERATURE RANGE	°F [°C]	-40 to 113 [-40 to 45]		
NOISE 1.5M DISTANCE	dB	<65		
HEATER	kWatts	5/10/15kW Options		
INPUT VOLTAGE /FREQUENCY	Volts/Hz	208/230 VAC, 1Ø 60Hz	208/230 VAC, 3Ø 60Hz	480 VAC, 3Ø 60Hz
COMPRESSOR RLA	Amps	20.5	16.0	7.7
COMPRESSOR LRA	Amps	115	115	50
CONDENSER HP	HP	1.5	1.5	1.5
EVAPORATOR FAN HP	HP	1.3	1.3	1.3
COOLING CURRENT MIN	Amps	35	20	10
COOLING CURRENT PROTECTION	Amps	40	25	15
EER [SP=0.1] / EER2 [SP=0.5]	--	11.0 / 12.0		
COP [HEAT PUMP MODE]	--	3.3		
APPROVALS	--	UL/Intertek ANSI/AHRI Standard 390-2021		
CONSTRUCTION	--	Galvanized & Galvanized Steel, Stainless Steel Optional Textured Powder Coat Standard, Color Options Available		

PrecisionAir® WS 5T

Dimensional Drawing

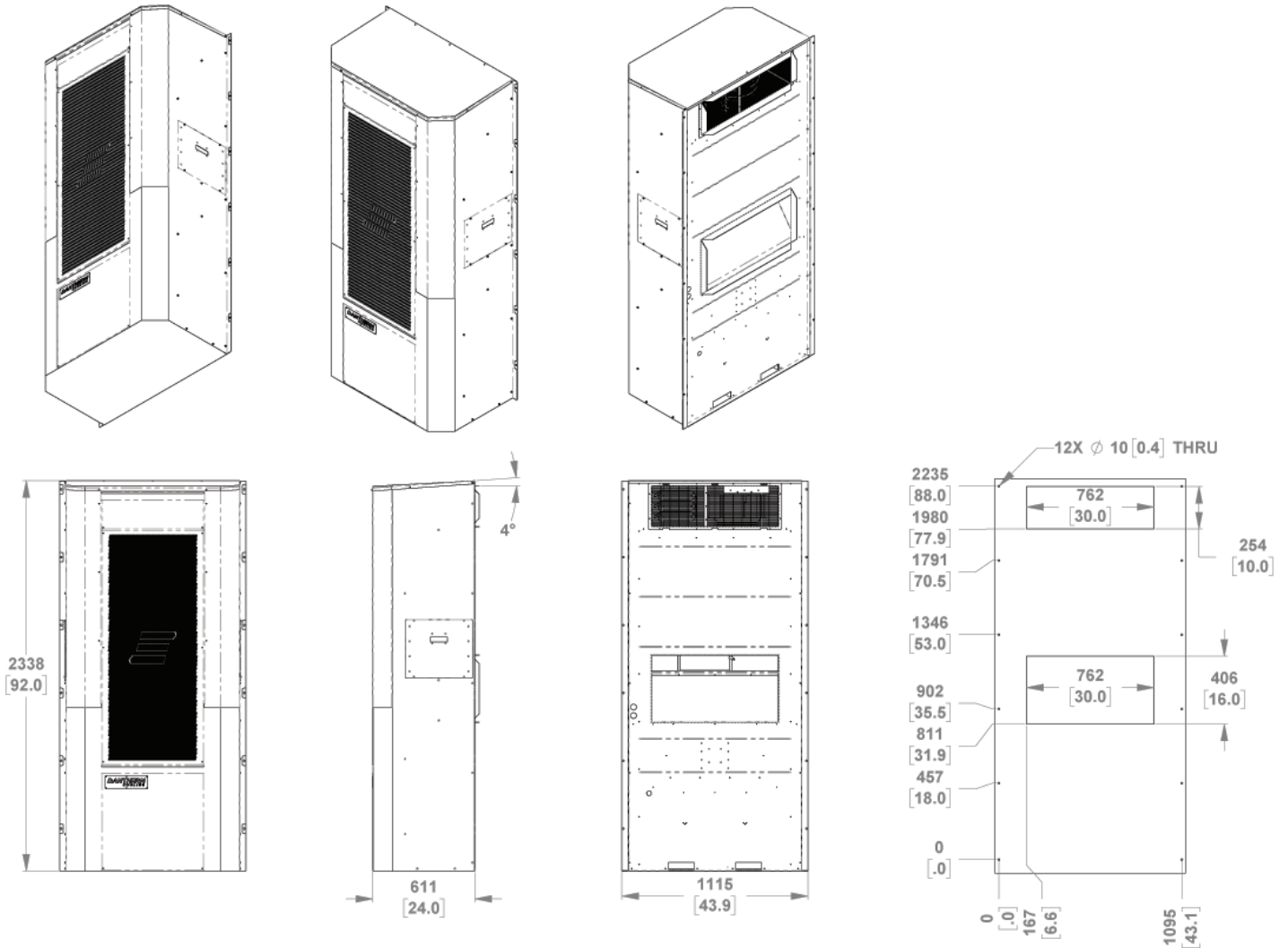

NOTES:

1. UNITS = MM [IN]
2. STEP FILE AVAILABLE UPON REQUEST
3. DO NOT SCALE DRAWING

PrecisionAir® WS 5T

Technical Data

	UNITS			
MODEL NUMBER	--	PA-WS-AC-60, PA-WS-HP-60		
MOUNTING TYPE	--	Vertical, Outdoor, NEMA/UL 3R, 4		
UNIT DIMENSIONS [HxWxD]	Inches [mm]	92x43.9x24.5 [2337x1115x622]		
WEIGHT	Lbs [kg]	475 [215.5]		
COOLING CAPACITY 80°F INTERNAL / 95°F AMBIENT	BTU/h [W]	60,000 [20kW]		
MAX INTERNAL AIRFLOW @ .5 IN H ₂ O	CFM [m ³ /h]	2,200 [3,800]		
MAX EXTERNAL AIRFLOW	CFM [m ³ /h]	3,600 [6,100]		
REFRIGERANT	Type	R410a or R454b [GWP=467]		
OPERATIONAL TEMPERATURE RANGE	°F [°C]	-40 to 113 [-40 to 45]		
NOISE 1.5M DISTANCE	dB	<65		
HEATER	kWatts	5/10/15kW Options		
INPUT VOLTAGE /FREQUENCY	Volts/Hz	208/230 VAC, 1Ø 60Hz	208/230 VAC, 3Ø 60Hz	480 VAC, 3Ø 60Hz
COMPRESSOR RLA	Amps	28.8	17.6	9.6
COMPRESSOR LRA	Amps	145	123	70
CONDENSER HP	HP	1.5	1.5	1.5
EVAPORATOR FAN HP	HP	1.3	1.3	1.3
COOLING CURRENT MIN	Amps	35	20	10
COOLING CURRENT PROTECTION	Amps	40	15	15
EER [SP=0.1] / EER2 [SP=0.5]	--	11.0 / 12.0		
COP [HEAT PUMP MODE]	--	3.3		
APPROVALS	--	UL/Intertek ANSI/AHRI Standard 390-2021		
CONSTRUCTION	--	Galvanized & Galvanized Steel, Stainless Steel Optional Textured Powder Coat Standard, Color Options Available		

PrecisionAir® SL 4T/5T

Dimensional Drawing

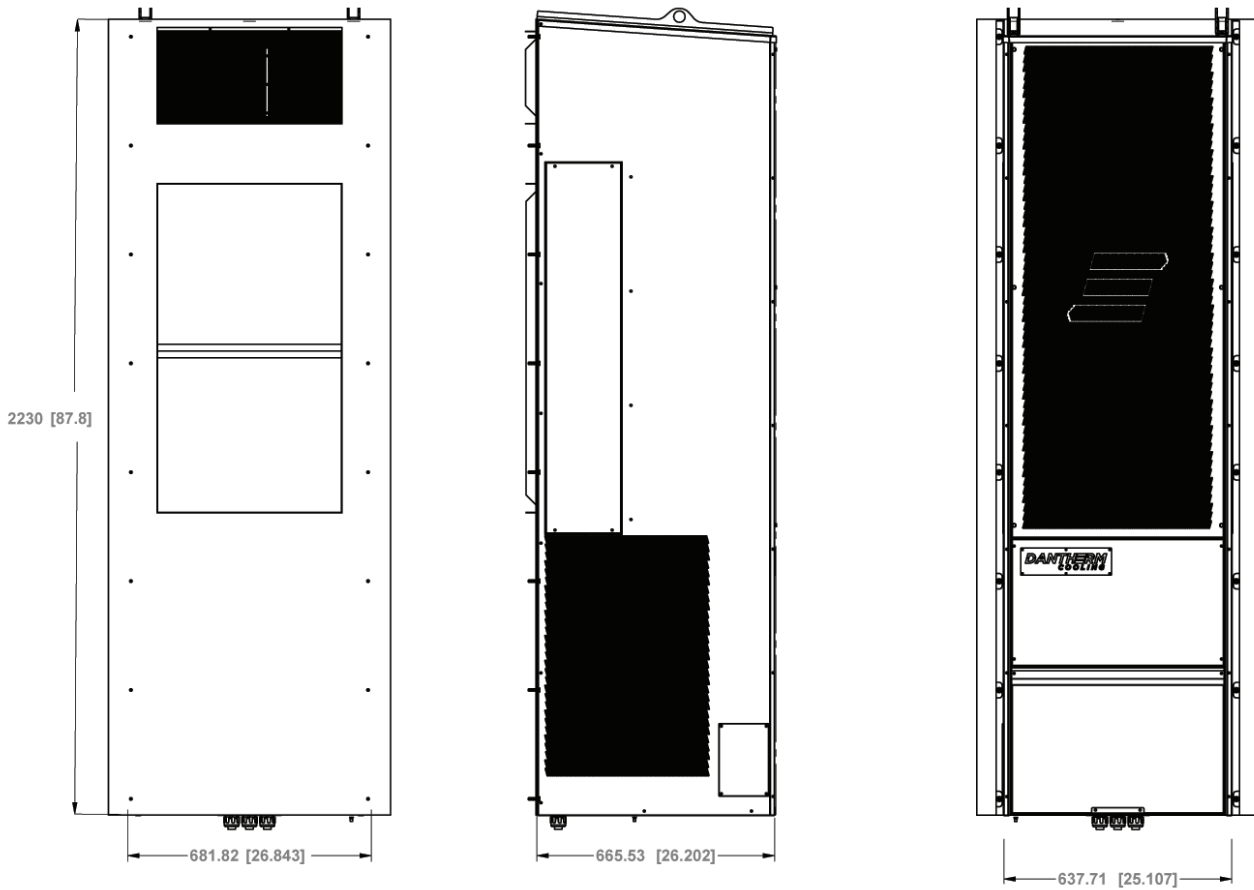

NOTES:

1. UNITS = MM [IN]
2. STEP FILE AVAILABLE UPON REQUEST
3. DO NOT SCALE DRAWING

PrecisionAir® SL 4T

Technical Data

	UNITS			
MODEL NUMBER	--	PA-SL-AC-48, PA-SL-HP-48		
MOUNTING TYPE	--	Vertical, Outdoor, NEMA/UL 3R, 4		
UNIT DIMENSIONS [HxWxD]	Inches [mm]	87.8x22.9x25.8 [2230x582x655]		
WEIGHT	Lbs [kg]	450 [204.1]		
COOLING CAPACITY 80°F INTERNAL / 95°F AMBIENT	BTU/h [W]	48,000 [14kW]		
MAX INTERNAL AIRFLOW @ .5 IN H ₂ O	CFM [m ³ /h]	2,160 [3,700]		
MAX EXTERNAL AIRFLOW	CFM [m ³ /h]	3,600 [6,100]		
REFRIGERANT	Type	R410a or R454b [GWP=467]		
OPERATIONAL TEMPERATURE RANGE	°F [°C]	-40 to 113 [-40 to 45]		
NOISE 1.5M DISTANCE	dB	72		
HEATER	kWatts	5/10/15kW Options		
INPUT VOLTAGE /FREQUENCY	Volts/Hz	208/230 VAC, 1Ø 60Hz	208/230 VAC, 3Ø 60Hz	480 VAC, 3Ø 60Hz
COMPRESSOR RLA	Amps	20.5	16.0	7.7
COMPRESSOR LRA	Amps	115	115	50
CONDENSER HP	HP	1.5	1.5	1.5
EVAPORATOR FAN HP	HP	1.3	1.3	1.3
COOLING CURRENT MIN	Amps	35	20	10
COOLING CURRENT PROTECTION	Amps	40	25	15
EER [SP=0.1] / EER2 [SP=0.5]	--	11.0 / 11.0		
COP [HEAT PUMP MODE]	--	3.3 / 3.3		
APPROVALS	--	UL/Intertek ANSI/AHRI Standard 390-2021		
CONSTRUCTION	--	Galvanized & Galvalume Steel, Stainless Steel Optional Textured Powder Coat Standard, Color Options Available		

PrecisionAir® SL 5T

Technical Data

	UNITS			
MODEL NUMBER	--	PA-SL-AC-60, PA-SL-HP-60		
MOUNTING TYPE	--	Vertical, Outdoor, NEMA/UL 3R, 4		
UNIT DIMENSIONS [HxWxD]	Inches [mm]	87.8x22.9x25.8 [2230x582x655]		
WEIGHT	Lbs [kg]	450 [204.1]		
COOLING CAPACITY 80°F INTERNAL / 95°F AMBIENT	BTU/h [W]	60,000 [20kW]		
MAX INTERNAL AIRFLOW @ .5 IN H ₂ O	CFM [m ³ /h]	2,160 [3,700]		
MAX EXTERNAL AIRFLOW	CFM [m ³ /h]	3,600 [6,100]		
REFRIGERANT	Type	R410a or R454b [GWP=467]		
OPERATIONAL TEMPERATURE RANGE	°F [°C]	-40 to 113 [-40 to 45]		
NOISE 1.5M DISTANCE	dB	72		
HEATER	kWatts	5/10/15kW Options		
INPUT VOLTAGE /FREQUENCY	Volts/Hz	208/230 VAC, 1Ø 60Hz	208/230 VAC, 3Ø 60Hz	480 VAC, 3Ø 60Hz
COMPRESSOR RLA	Amps	28.8	17.6	8.3
COMPRESSOR LRA	Amps	145	123	70
CONDENSER HP	HP	1.5	1.5	1.5
EVAPORATOR FAN HP	HP	1.3	1.3	1.3
COOLING CURRENT MIN	Amps	35	20	10
COOLING CURRENT PROTECTION	Amps	40	25	15
EER [SP=0.1] / EER2 [SP=0.5]	--	11.0 / 11.0		
COP [HEAT PUMP MODE]	--	3.3 / 3.3		
APPROVALS	--	UL/Intertek ANSI/AHRI Standard 390-2021		
CONSTRUCTION	--	Galvanized & Galvalume Steel, Stainless Steel Optional Textured Powder Coat Standard, Color Options Available		

PREVENTATIVE MAINTENANCE

Preventive maintenance must be completed in order to:

- Continue operation in specified range
- Avoid malfunctions
- Avoid inefficient operation
- Maximize the unit's lifetime

The factory warranty is only valid if documented preventive maintenance has been carried out, with a time interval of:

- Maximum 6 months when unit is located in normal air quality environment.
- Maximum 2 months when unit is located in bad air quality environment.

A written log at site is adequate documentation for preventive maintenance.

⚠ CAUTION

- Switch off power supply before working on the unit
- Make sure that all work has been performed correctly before switching power back on

The unit must be cleaned according to the recommended preventive maintenance plan.

Tools required:

- Vacuum cleaner or compressed air
- Soft brush
- TORX 20 and 25 Security Driver
- AC cleaning agent as needed

PHASE	DESCRIPTION
1	Check and clean the outside air inlet grill if needed.
2	Open the units outer cover by removing the two screws in the lower edge of the cover.
3	Vacuum the condenser coil and the visible part of the fan.
4	Vacuum the evaporator coil from the inside of the enclosure.
5	If any of the coils are still dirty, apply AC cleaning agent on coil fins, and after 5 minutes gently rinse off with water, WITHOUT spraying water on any electrical parts.
6	Perform final inspection according to the list in the next section.

INSPECTION

The unit must be inspected before it is reassembled and put back into service. Please follow the steps below:

PHASE	DESCRIPTION
1	Are the fans clean and free of any corrosion?
2	Are the coolant pipes free of obstructions, damage, corrosion and show no obvious signs of leakage?
3	Are the coils clean and undamaged?
4	Are all fan blades free of any obstructions, cracks or missing blades?
5	When manually rotating the fans, do the fans rotate freely, without vibrations and noise?
6	Is all wiring and insulation undamaged?
7	Are all connector secured properly and in good condition?
8	Inspect the drain hose (if any) for damage or obstruction.
9	Are there any alarms visible on the controller?

TEST COOLING CIRCUIT

The cooling circuit is designed for long durability, and is based only on a few components. Any testing of the circuit should be conducted, only if, a relevant problem has arisen. Open the unit's outside cover, by removing the two screws in the lower part. Locate the service valve, connect a pressure gauge, and check that the pressure is aligned with the present temperature. Due to critical refrigerant changes, low volume refrigeration hoses with low loss fittings should be used when accessing the refrigeration system. Care should be taken to minimize any amount of lost refrigerant.

SPARE PARTS

A number of spare and replacement parts are available from Dantherm Cooling. Please contact technical support for more information at:

tech.support@danthermcooling.com

WARRANTY:

DANTHERM COOLING, INC., HEAT EXCHANGERS AND AIR CONDITIONING UNITS HAVE LIMITED WARRANTY.

DANTHERM COOLING, INC. ("DANTHERM") limited warranty extends to the original purchaser only of any DANTHERM heat exchanger and air conditioning unit, and to no other person or entity. DANTHERM warrants that such DANTHERM products will be free from defects in materials and workmanship in normal use for a period of twelve (12) months from the date of the original purchase. Should any part of your DANTHERM product fail because of a manufacturing defect within such twelve (12) month period, DANTHERM terms are set out below.

IMPORTANT

- Using Dantherm nominated service contractors – warranty on product continues.
- Using Dantherm non-approved service contractors – warranty on product becomes void.
- Warranty period starts from date of shipment – warranty of replacement parts shall only apply for the remainder of the warranty period of the original product.

Any transportation, related service labor, diagnosis calls, filters, driers, and refrigerant are not included.

In the event all related service labor is performed by DANTHERM nominated service contractors, the replacement part shall be warranted by DANTHERM for the remainder of the warranty period for the original product.

This warranty does not cover damages or repairs caused by improper installation, misuse of the product, negligent servicing, improper applications, unauthorized modifications, improper electrical supply, failure to follow manufacturer's instructions and rating plate information, accidents, natural disasters, damage in transportation, lack of normal preventive maintenance, or other events beyond DANTHERM's control.

This warranty is also subject to the following operating conditions:

- 1) Voltage variation not greater than 10%,
- 2) Frequency variation not greater than 3Hz from nameplate rating
- 3) Cooling load is not greater than product label under rated conditions
- 4) Unit is not restarted for a period of five minutes after accidental or intentional shut-off
- 5) Operation is not subject to abnormal conditions or customer, user misapplication
- 6) Customer or user does not modify, abuse, or neglect the product
- 7) Refrigerant specified on nameplate is only refrigerant used
- 8) Customer or user complies with all other installation, maintenance, and operating instructions. Cost of repair or replacement of consumable parts is not covered under the terms of this warranty.

THIS WARRANTY CONSTITUTES THE EXCLUSIVE REMEDY OF ANY PURCHASER OF A DANTHERM HEAT EXCHANGER, AIR CONDITIONING UNIT AND IS IN LIEU OF ALL OTHER WARRANTIES. THIS ALSO INCLUDES, WITHOUT LIMITATION, ANY IMPLIED WARRANTIES OF MERCHANTABILITY, FITNESS FOR USE, OR FOR A PARTICULAR PURPOSE. IN NO EVENT SHALL ANY IMPLIED WARRANTIES OF MERCHANTABILITY, FITNESS FOR USE, OR FOR A PARTICULAR PURPOSE EXCEED THE TERMS OF THE APPLICABLE WARRANTY STATED ABOVE, AND DANTHERM SHALL HAVE NO OTHER OBLIGATION OR LIABILITY, EXPRESS OR IMPLIED. IN NO EVENT SHALL DANTHERM BE LIABLE FOR ANY INCIDENTAL OR CONSEQUENTIAL DAMAGES. THIS WARRANTY GIVES YOU SPECIFIC LEGAL RIGHTS, AND YOU MAY ALSO HAVE OTHER RIGHTS WHICH VARY FROM STATE TO STATE. SOME STATES DO NOT ALLOW LIMITATIONS OR EXCLUSIONS, SO THE ABOVE LIMITATIONS AND EXCLUSIONS MAY NOT APPLY TO YOU.

RETURN MATERIAL AUTHORIZATION PROCEDURE

In the unlikely event of unit failure, the following return procedure shall be adopted.

- All product returns require a Return Material Authorization number regardless of reason.
- The customer is required to contact the Quality Department at Dantherm Cooling, Inc. in Spartanburg, SC at +1- 864- 595- 9800 to obtain an RMA number.
- The following information must be provided prior to a RMA number being issued:
 - Dantherm Cooling, Inc. part number(s) of product to be returned.
 - Dantherm Cooling, Inc. serial number(s) of product to be returned.
 - Number of units requested to be returned.
 - Reason for return.
 - Contact name, phone and fax number.
 - Date of product receipt.
 - Invoice number and purchase order number covering the unit(s).
- The customer is responsible for suitably packaging the unit(s) securely, ideally in the original packaging, marking all cartons with the RMA number and shipping them prepaid to the designated site specified by Dantherm Cooling, Inc.

IN NO EVENT SHALL DANTHERM COOLING, INC. ACCEPT ANY SHIPMENT WHICH DOES NOT COMPLY WITH THE ABOVE PROCEDURES.

REMOVE THE CONDENSATE HOSE AND ADAPTER FROM THE BOTTOM OF THE UNITS PRIOR TO DISMANTLING THE AIR CONDITIONER AND RESTING IT ON THE GROUND.

DECLARATION OF CONFORMITY

Dantherm Cooling Inc., Spartanburg, SC hereby declare that the units PrecisionAir 50/60Hz are in conformity with the following directives:

UL 60335-1 Fifth Edition
 UL 60335-2-40 First Edition
 CAN/CSA-C22.2 No. 60335-1-11 First Edition
 CAN/CSA-C22.2 No. 60335-2-40 .. First Edition
 Spartanburg, SC – September.20.2018

Recycling: The unit should be recycled according to national rules and procedures to protect the environment. Please consult your local authorities for further information.

DANTHERM COOLING

DANTHERMCOOLING.COM

TECH.SUPPORT@DANTHERMCOOLING.COM | 864-595-9800

671 SPRINGFIELD ROAD | SPARTANBURG, SOUTH CAROLINA 29303