

DANTHERM

COOLING

HexFlow® Series

Energy Efficient Temperature Control and Closed-Loop Cooling



DANTHERM
COOLING

TECH.SUPPORT@DANTHERMCOOLING.COM 864-595-9800
671 SPRINGFIELD ROAD SPARTANBURG, SOUTH CAROLINA 29303



About Dantherm Cooling

Performance Cooling

Over the past 28 years, Dantherm cooling has established itself as a leader in innovative cooling systems, supplying more than 350,000 climate control units to mission critical applications. By applying our passion for performance and quality throughout our company, we have become known for providing outstanding products and an exceptional customer experience.

Our innovative, highly engineered product lines feature industry leading technology to deliver outstanding performance, operate efficiently and perform reliably in extreme climate conditions. Backed by our experienced design team, quality manufacturing processes and extensive testing and certification practices, Dantherm Cooling can provide customers with engineered solutions to their most challenging applications.

Our passion and success in building an industry leading business compels us to invest in those around us. From our employee centric culture, to our ongoing community outreach, we are committed to use our business as a catalyst for positivity in the lives of those around us.



HexFlow[®]

Dantherm Cooling's HexFlow cooling systems feature high heat-removing performance, low power consumption, minimal maintenance requirements and reduced noise emissions, making the HexFlow system a great choice for maintaining an ideal temperature-range for electrical equipment, electronics and other heat-sensitive systems.

Dantherm's heat exchanger technology uses an air-to-air closed-loop heat exchange circuit that extracts heat from the enclosure's interior and replaces it with cooler air, providing continuous heat removal and cooling to the equipment inside the enclosure. High static pressure BCI fans ensure maximum airflow and counteract high static pressure resistance in densely-populated electrical enclosures. The Dantherm HexFlow system is close-looped, filterless and CFC and refrigerant-free, providing an environmentally-friendly, reliable, low maintenance, and low operating cost cooling solution that can often be installed without powering down the site.

HexFlow®

Energy Efficient Temperature Control and Closed-Loop Cooling For Electrical Gear and Mechanical Equipment Enclosures

Utilizing innovative design and technology to produce performance cooling has been part of our history dating back to 1958. Our ThermoFlow systems utilize our extensive engineering and manufacturing expertise to deliver an energy-efficient and powerful cooling solution.

All of our products are manufactured to tight tolerances and thoroughly tested before they leave our factory. With over 350,000+ units operating in the field, customers can be assured of long life and industry leading performance.

- Filterless design requires little to no service
- Compact, lightweight units with easy installation
- Efficiency coated aluminum cross-flow core
- Quality, high-performance, high-static pressure fans with controller allows performance tuning
- Environmentally-friendly design, CFC and refrigerant-free
- Designed in accordance with GR-487 specifications
- Fan speed controller with alarm output
- Stainless steel material and custom paint finishes

Engineered Performance

Designed to Meet Demanding Customer Requirements

Innovative Design

Patent-pending thermosiphon technology increases efficient passive cooling process and lowers operating costs

Powerful Cooling

High-performance, high-static pressure fans deliver improved passive cooling capacity

Energy Savings

Innovative design and high quality performance components deliver high energy efficiency



Reliable

Closed-loop design and weatherproof enclosure for most challenging environment

Tuned Performance

Adjust fan speeds and tune performance for each installation

Low Maintenance

Lightweight and easy to install with minimal maintenance requirements

HexFlow®

Verified Performance, Quality Assured

Dantherm Cooling's commitment to high-quality innovation, manufacturing and customer support is demonstrated by the standards we keep.

Our products are routinely used in critical infrastructure applications where our customers require the highest performance, quality and reliability standards. Third party certification and verification gives customers a sense of security knowing that our products have been independently tested to perform to the caliber we claim.

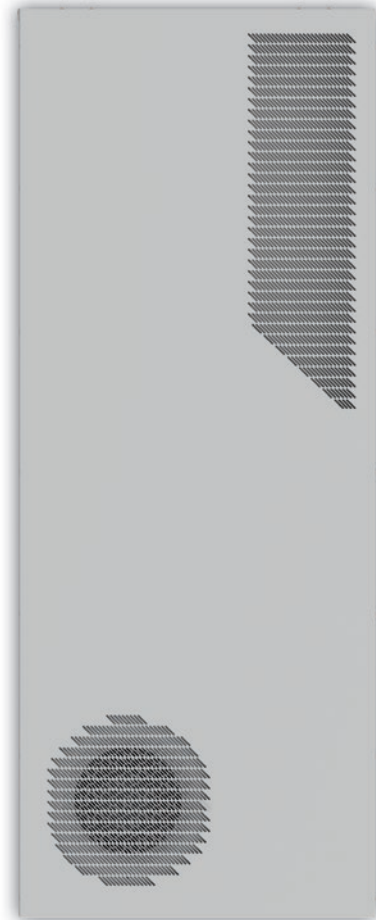

Dantherm Cooling's ISO 9001:2105 certification demonstrates that our business and manufacturing processes meet all international standards for the consistent delivery of high-quality products and services. Regular audits and process reviews ensure consistent manufacturing performance.



Through our partnership with Underwriter's Laboratory (UL), UL has certified that all Dantherm Cooling materials and products, as well as specific testing procedures and documentation, have been thoroughly inspected for safety and quality, and meet or exceed established standard requirements.

HF-45-230-T1

CAPACITY

17 - 17 W/°F
22 - 22 W/°F
26 - 26 W/°F
35 - 35 W/°F
45 - 45 W/°F
55 - 55 W/°F
100 - 100 W/°F
200 - 200 W/°F

VOLTAGE

115 - 115 volt / single phase
230 - 230 volt / single phase
24 - 24 VDC
48 - 48 VDC

OPTIONS

L - EXTERNAL PLUG
M - STAINLESS STEEL COVER
PXX - NON STANDARD PAINT COLOR
S - SPEED CONTROLLER
T1 - EXTERNAL FAN THERMOSTAT

Note: Legacy model number nomenclature contained the following elements (for reference only):

“P” - Pinnacle Series HexFlow

“S” - Standard Unit Type

“OXX” - Designated Nominal Height

Example Model Number: P-S-035-045-230-T1

Speed Control (-S)

The controller is designed to slow down the speed of the internal and external fans at lower temperatures to reduce noise and energy consumption. It will also supply either a normally closed (NC) or normally open (NO) alarm signal for fan fault, sensor fault, or high temperature.

Thermostat Control (-T1)

A snap disc thermostat controls the operation of the external loop fan. A temperature rise above 80°F will cause the fan to be turned on, a temperature decrease below 60°F will cause the fan to be turned off; between the range of 60°F-80°F the fan will be operating based on the previous environmental condition experienced.

This page intentionally left blank

HexFlow® 17SQ*

Capacity Curve & Dimensional Drawings

*Also available in Surface Mount

Heat Removal at Recommended ΔT

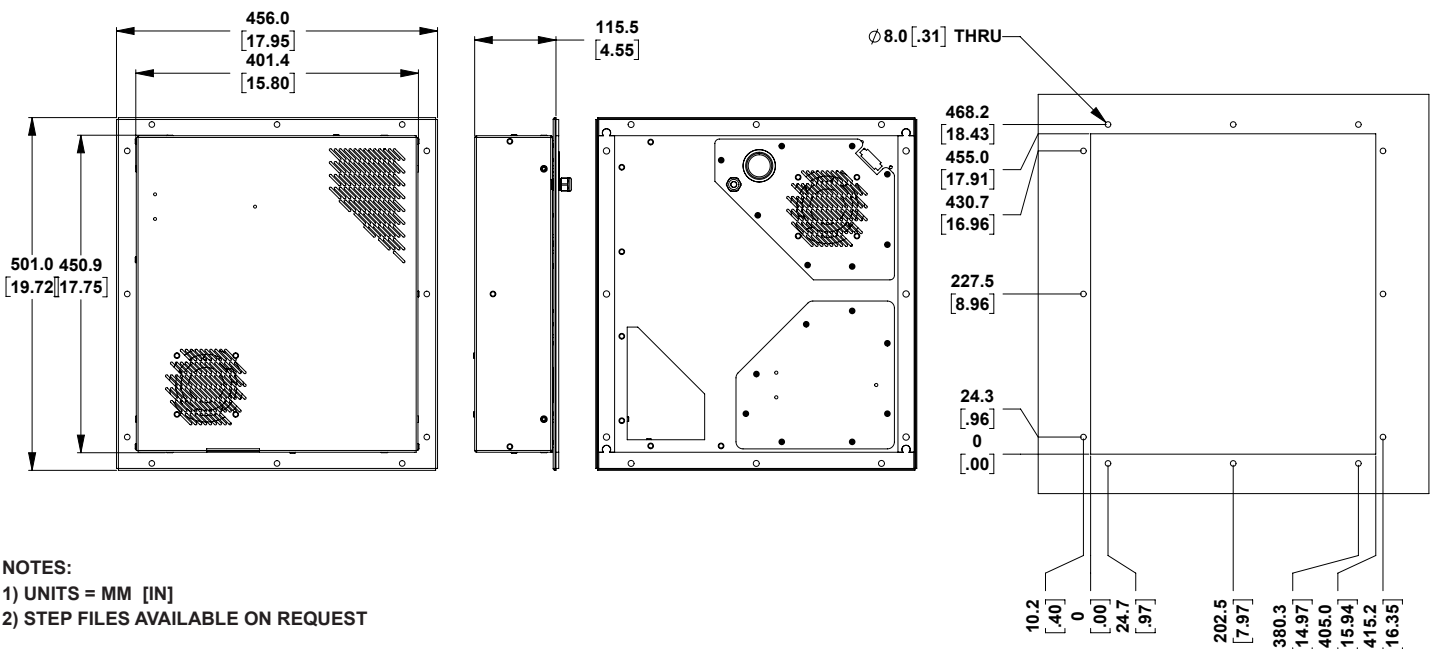
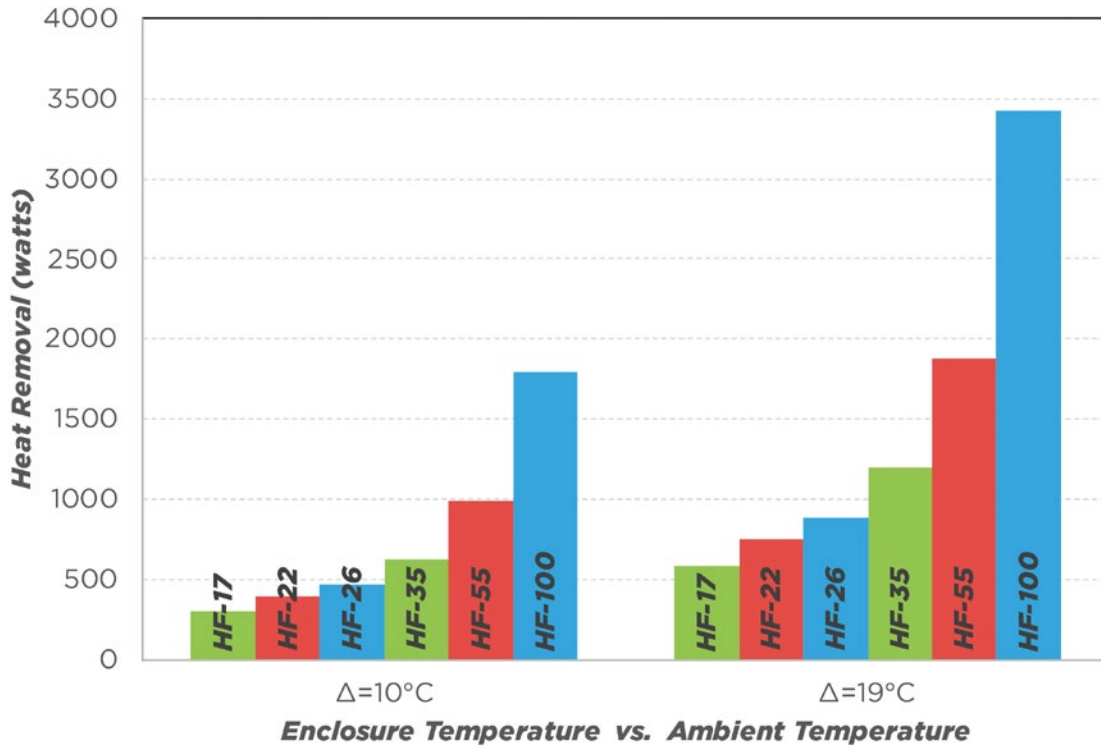

HexFlow® 17SQ

Technical Data

	UNITS				
MODEL NUMBER	--	HF-17-115-SQ	HF-17-230-SQ	HF-17-24-SQ	HF-17-48-SQ
MOUNTING TYPE	--	Outdoor			
UNIT DIMENSIONS [HxWxD]	Inches [mm]	48.5x19.5x14.4 [457.2x406.4x114.3]			
WEIGHT	Lbs [kg]	21 [9.5]			
COOLING CAPACITY 131°F INTERNAL / 131°F AMBIENT	W/°F [W/°C]	17 [30]			
OPERATIONAL TEMPERATURE RANGE	°F [°C]	-40 to 149 [-40 to 65]			
NOISE 1.5M DISTANCE	dB	65			
INPUT VOLTAGE	Volts	120 VAC	240 VAC	24V DC	48V DC
CURRENT	Amps	0.5	0.3	1.75	2.3
APPROVALS	--	SA12349 (UL)			
CONSTRUCTION	--	Aluzink Steel, Stainless Optional Textured Powder Coat, Color Options Available			

HexFlow® 17

Capacity Curve & Dimensional Drawings

Heat Removal at Recommended ΔT

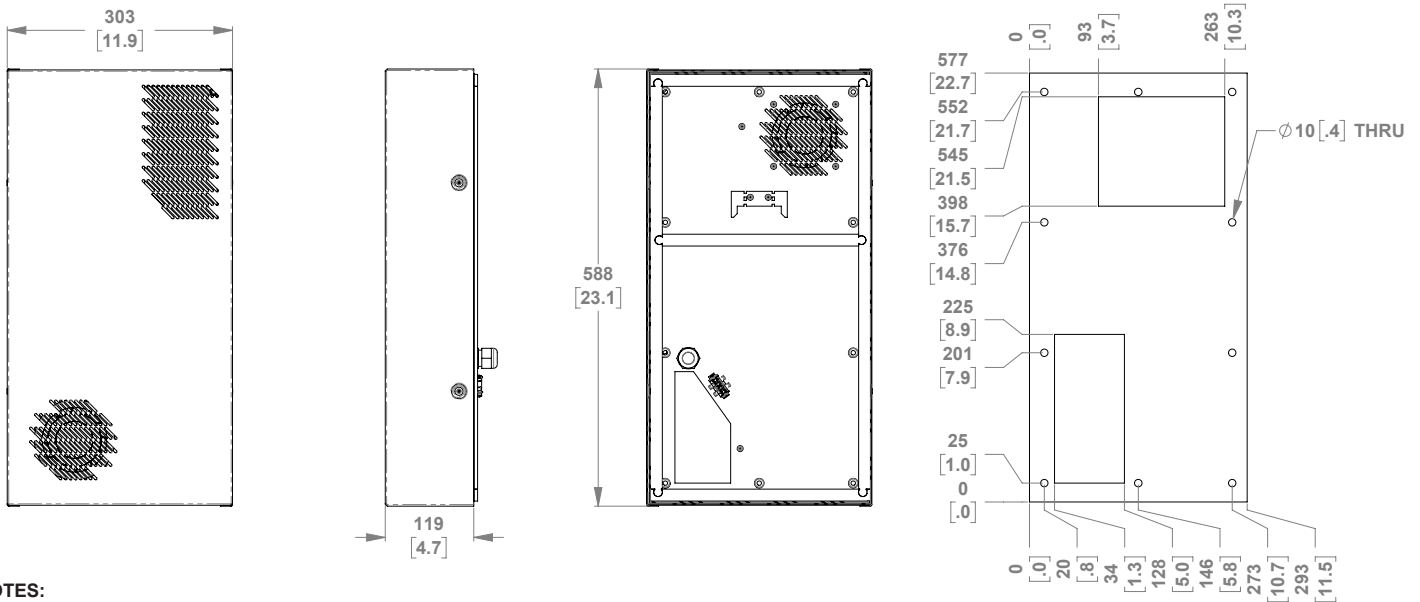
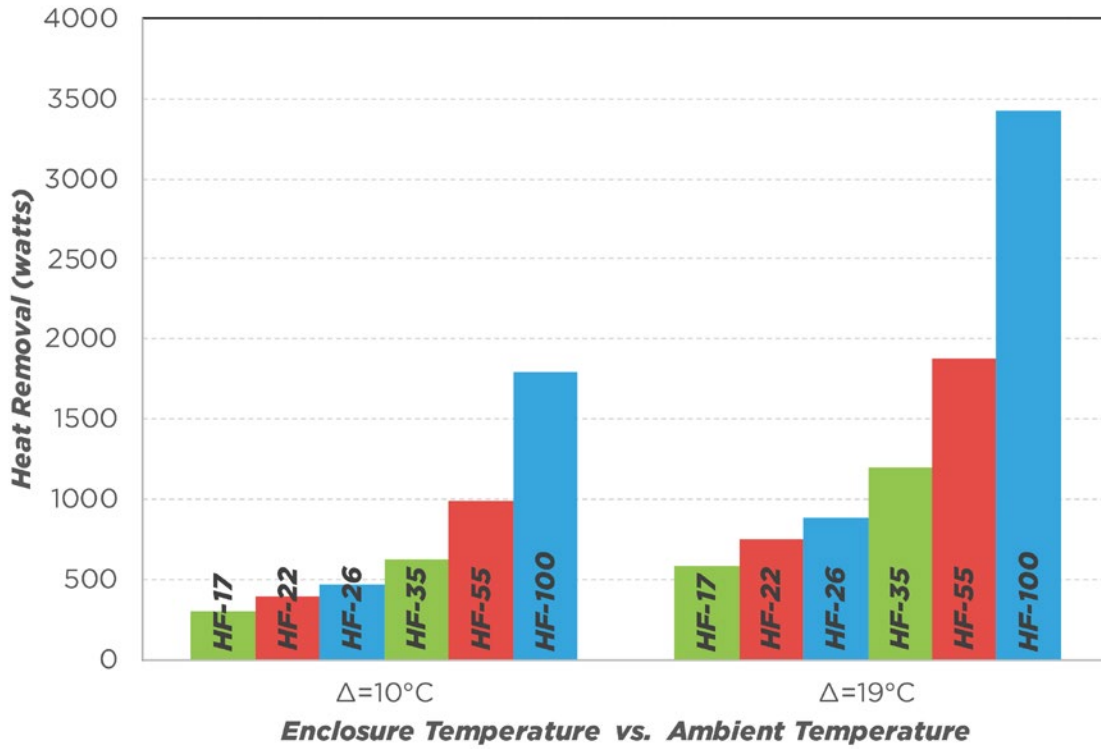

- NOTES:**
 1) UNITS = MM [IN]
 2) STEP FILES AVAILABLE ON REQUEST

HexFlow® 17

Technical Data

	UNITS				
MODEL NUMBER	--	HF-17-115	HF-17-230	HF-17-24	HF-17-48
MOUNTING TYPE	--	Outdoor			
UNIT DIMENSIONS [HxWxD]	Inches [mm]	23x12x4.7 [584.2x304.8x170]			
WEIGHT	Lbs [kg]	21 [9.5]			
COOLING CAPACITY 131°F INTERNAL / 131°F AMBIENT	W/°F [W/°C]	17 [30]			
OPERATIONAL TEMPERATURE RANGE	°F [°C]	-40 to 149 [-40 to 65]			
NOISE 1.5M DISTANCE	dB	65			
INPUT VOLTAGE	Volts	120 VAC	240 VAC	24V DC	48V DC
CURRENT	Amps	0.5	0.3	1.75	2.3
APPROVALS	--	SA12349 (UL)			
CONSTRUCTION	--	Aluzink Steel, Stainless Optional Textured Powder Coat, Color Options Available			

HexFlow® 22

Capacity Curve & Dimensional Drawings

Heat Removal at Recommended ΔT

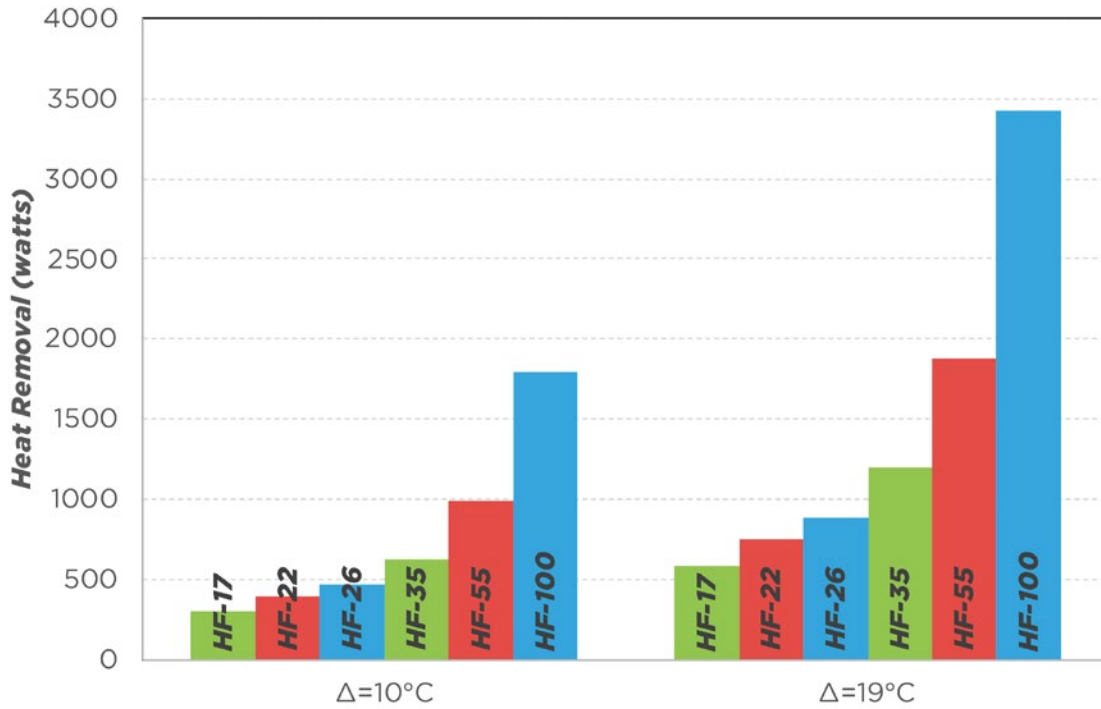

Enclosure Temperature vs. Ambient Temperature

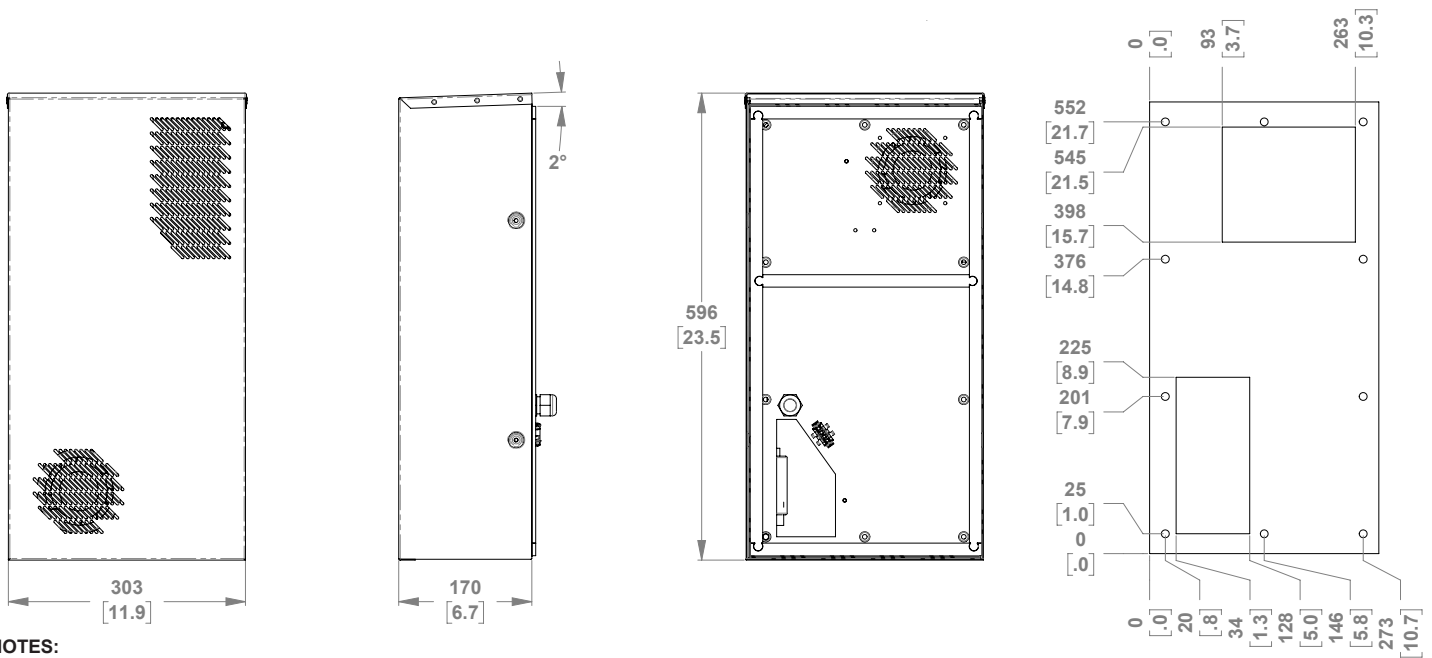

- NOTES:
- 1) UNITS = MM [IN]
 - 2) STEP FILES AVAILABLE ON REQUEST

HexFlow® 22

Technical Data

	UNITS				
MODEL NUMBER	--	HF-22-115	HF-22-230	HF-22-24	HF-22-48
MOUNTING TYPE	--	Outdoor			
UNIT DIMENSIONS [HxWxD]	Inches [mm]	23x12x7 [584.2x304.8x177.8]			
WEIGHT	Lbs [kg]	23 [10.5]			
COOLING CAPACITY 131°F INTERNAL / 131°F AMBIENT	W/°F [W/°C]	22 [40]			
OPERATIONAL TEMPERATURE RANGE	°F [°C]	-40 to 149 [-40 to 65]			
NOISE 1.5M DISTANCE	dB	65			
INPUT VOLTAGE	Volts	120 VAC	240 VAC	24V DC	48V DC
CURRENT	Amps	0.5	0.3	1.75	2.3
APPROVALS	--	SA12349 (UL)			
CONSTRUCTION	--	Aluzink Steel, Stainless Optional Textured Powder Coat, Color Options Available			

HexFlow® 26

Capacity Curve & Dimensional Drawings

*NEMA 4 Option Available

Heat Removal at Recommended ΔT

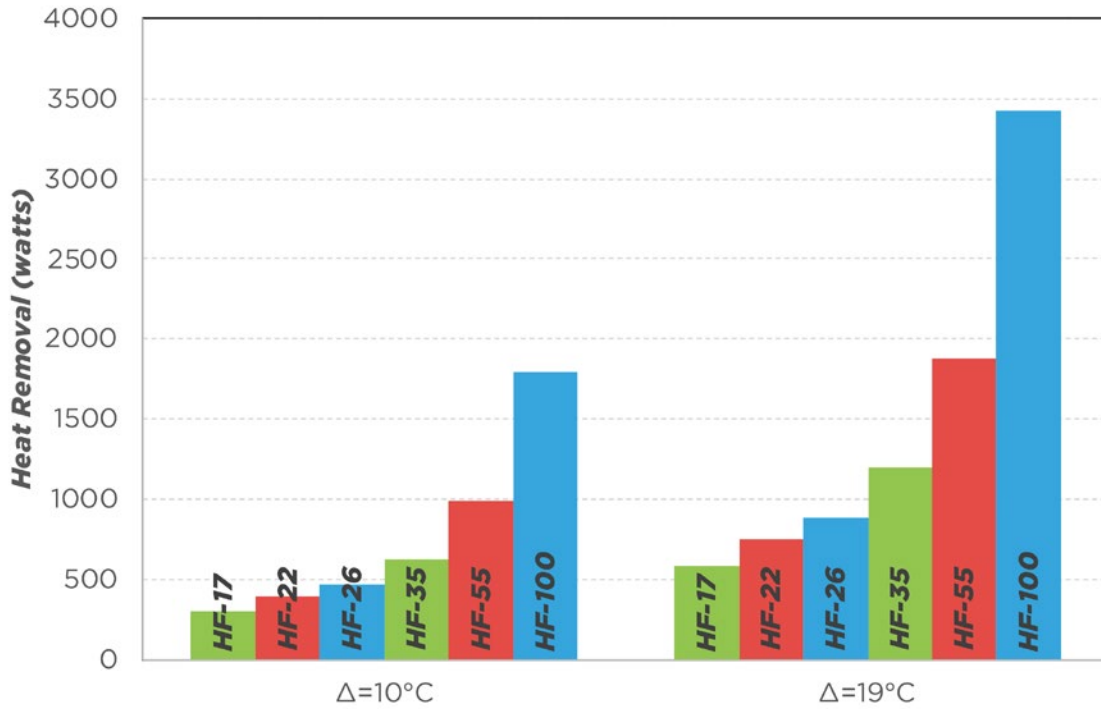

Enclosure Temperature vs. Ambient Temperature

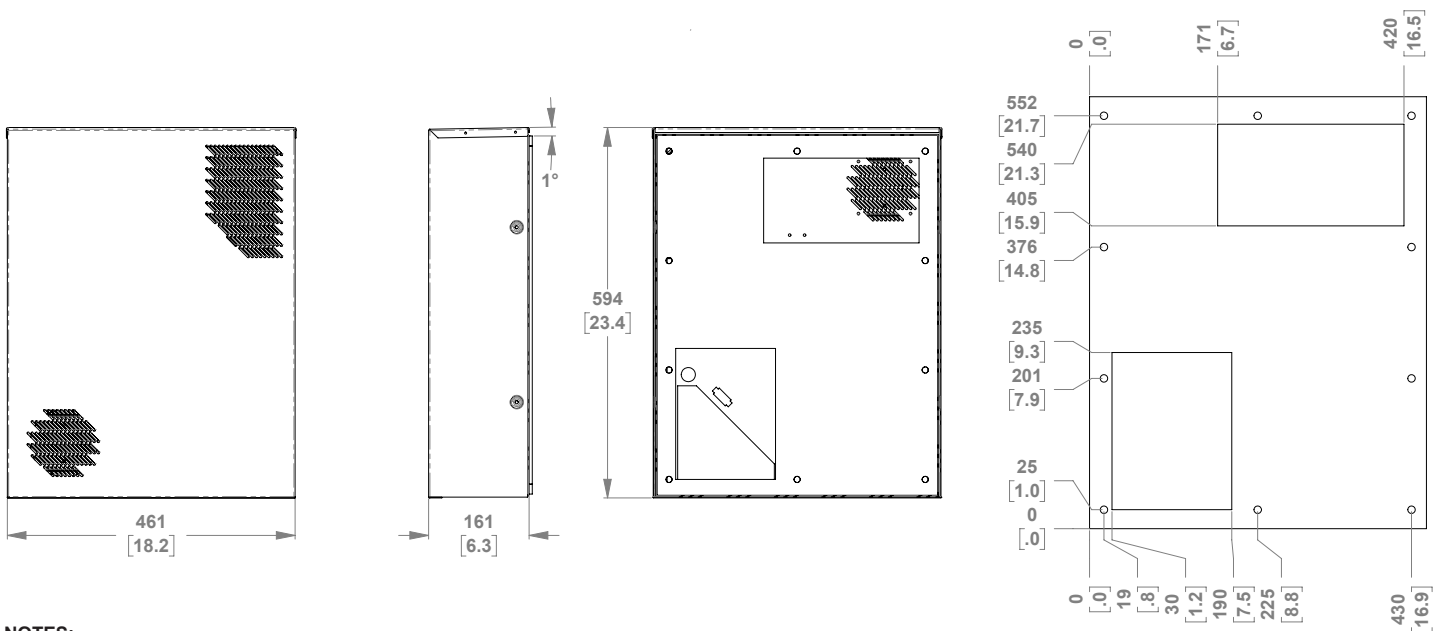

NOTES:

- 1) UNITS = MM [IN]
- 2) STEP FILES AVAILABLE ON REQUEST

HexFlow® 26

Technical Data

	UNITS				
MODEL NUMBER	--	HF-22-115	HF-22-230	HF-22-24	HF-22-48
MOUNTING TYPE	--	Outdoor			
UNIT DIMENSIONS [HxWxD]	Inches [mm]	23x12x7 [584.2x304.8x177.8] 24.4x18.3x10 [616x465x255] NEMA			
WEIGHT	Lbs [kg]	23 [10.5]			
COOLING CAPACITY 131°F INTERNAL / 131°F AMBIENT	W/°F [W/°C]	22 [40]			
OPERATIONAL TEMPERATURE RANGE	°F [°C]	-40 to 149 [-40 to 65]			
NOISE 1.5M DISTANCE	dB	65			
INPUT VOLTAGE	Volts	120 VAC	240 VAC	24V DC	48V DC
CURRENT	Amps	0.5	0.3	1.75	2.3
APPROVALS	--	SA12349 (UL)			
CONSTRUCTION	--	Aluzink Steel, Stainless Optional Textured Powder Coat, Color Options Available			
SUBMERSION RATING	--	NEMA 4 Optional Add N4 To End of Model Number			

HexFlow® 35

Capacity Curve & Dimensional Drawings

Heat Removal at Recommended ΔT

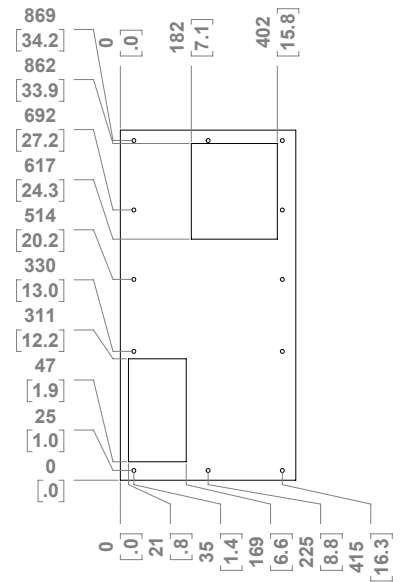
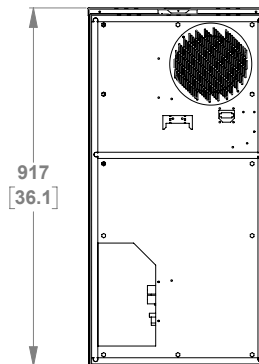
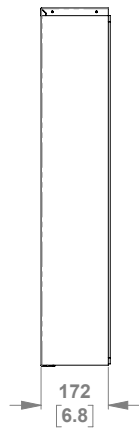
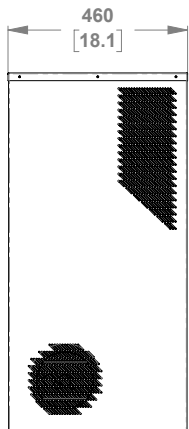
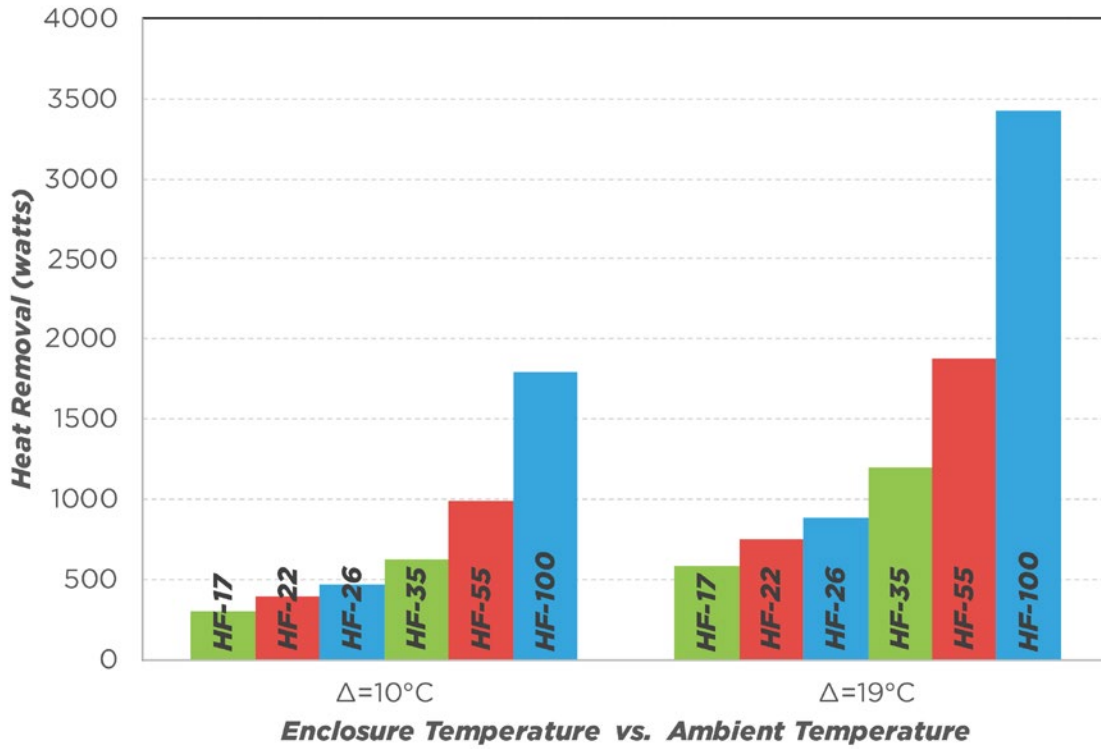

- NOTES:
 1) UNITS = MM [IN]
 2) STEP FILES AVAILABLE ON REQUEST

HexFlow® 35

Technical Data

	UNITS				
MODEL NUMBER	--	HF-35-115	HF-35-230	HF-35-24	HF-35-48
MOUNTING TYPE	--	Outdoor			
UNIT DIMENSIONS [HxWxD]	Inches [mm]	36x18x6.8 [914.4x457.2x172.72]			
WEIGHT	Lbs [kg]	59 [26.8]			
COOLING CAPACITY 131°F INTERNAL / 131°F AMBIENT	W/°F [W/°C]	35 [65]			
OPERATIONAL TEMPERATURE RANGE	°F [°C]	-40 to 140 [-40 to 60]			
NOISE 1.5M DISTANCE	dB	66		72	
INPUT VOLTAGE	Volts	115 VAC	230 VAC	24V DC	48V DC
CURRENT	Amps	3.4	.86	8.0	3.96
APPROVALS	--	SA12349 (UL)			
CONSTRUCTION	--	Aluzink Steel, Stainless Optional Textured Powder Coat, Color Options Available			

HexFlow® 55

Capacity Curve & Dimensional Drawings

Heat Removal at Recommended ΔT

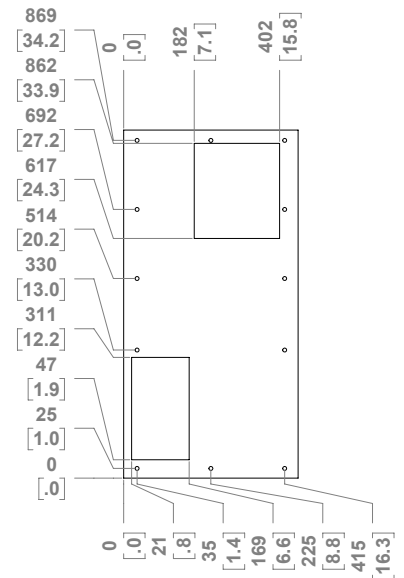
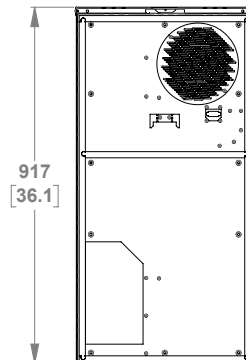
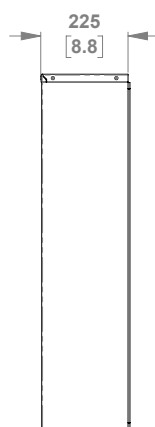
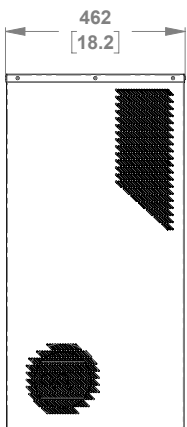
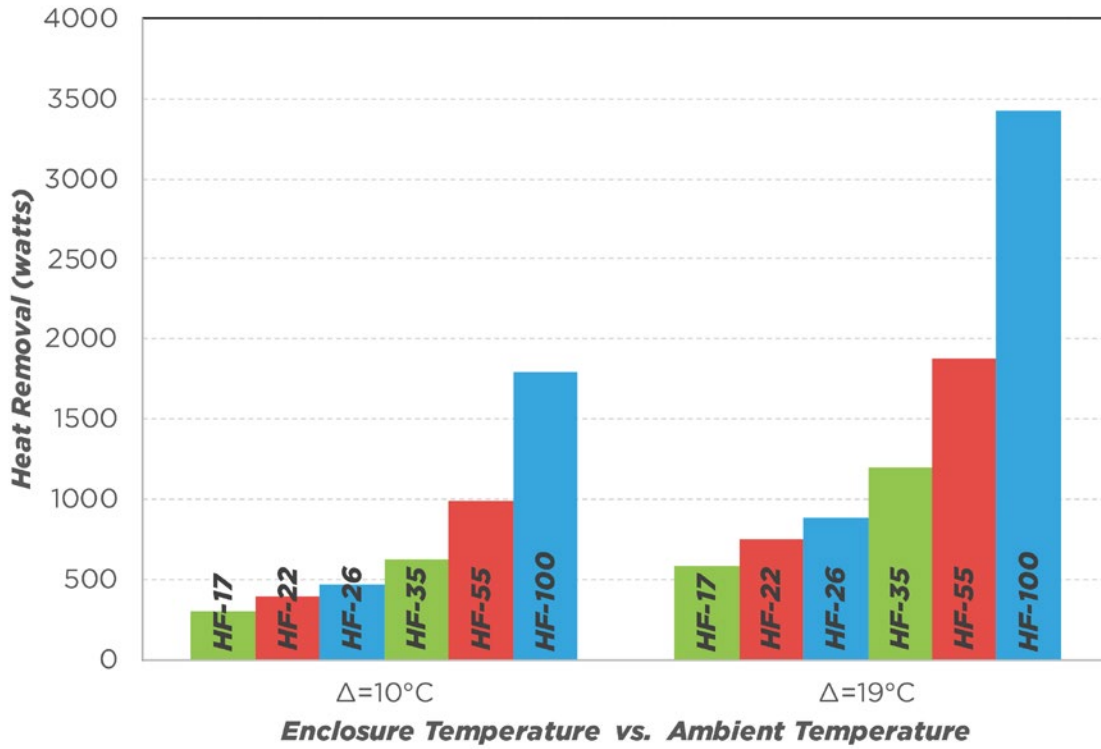

NOTES:

- 1) UNITS = MM [IN]
- 2) STEP FILES AVAILABLE ON REQUEST

HexFlow® 55

Technical Data

	UNITS				
MODEL NUMBER	--	HF-55-115	HF-55-230	HF-55-24	HF-55-48
MOUNTING TYPE	--	Outdoor			
UNIT DIMENSIONS [HxWxD]	Inches [mm]	36x18x8.8 [914.4x457.2x223.52]			
WEIGHT	Lbs [kg]	70 [31.8]			
COOLING CAPACITY 131°F INTERNAL / 131°F AMBIENT	W/°F [W/°C]	55 [99]			
OPERATIONAL TEMPERATURE RANGE	°F [°C]	-40 to 140 [-40 to 60]			
NOISE 1.5M DISTANCE	dB	72			
INPUT VOLTAGE	Volts	115 VAC	230 VAC	24V DC	48V DC
CURRENT	Amps	3.4	1.86	8.6	4.3
APPROVALS	--	SA12349 (UL)			
CONSTRUCTION	--	Aluzink Steel, Stainless Optional Textured Powder Coat, Color Options Available			

HexFlow® 100

Capacity Curve & Dimensional Drawings

Heat Removal at Recommended ΔT

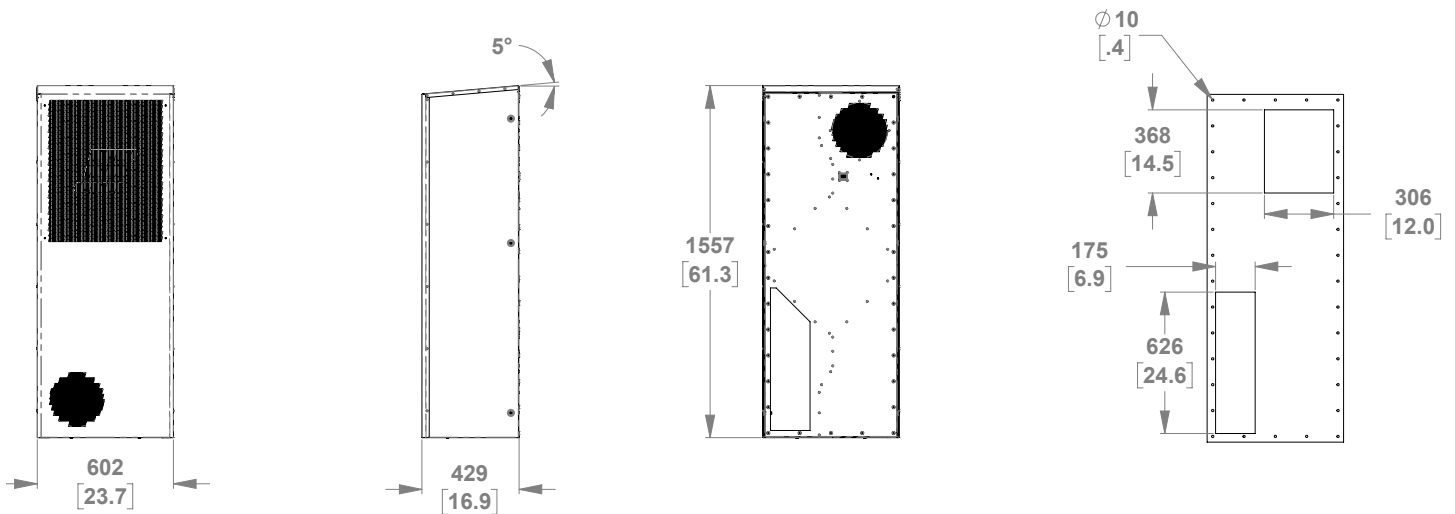
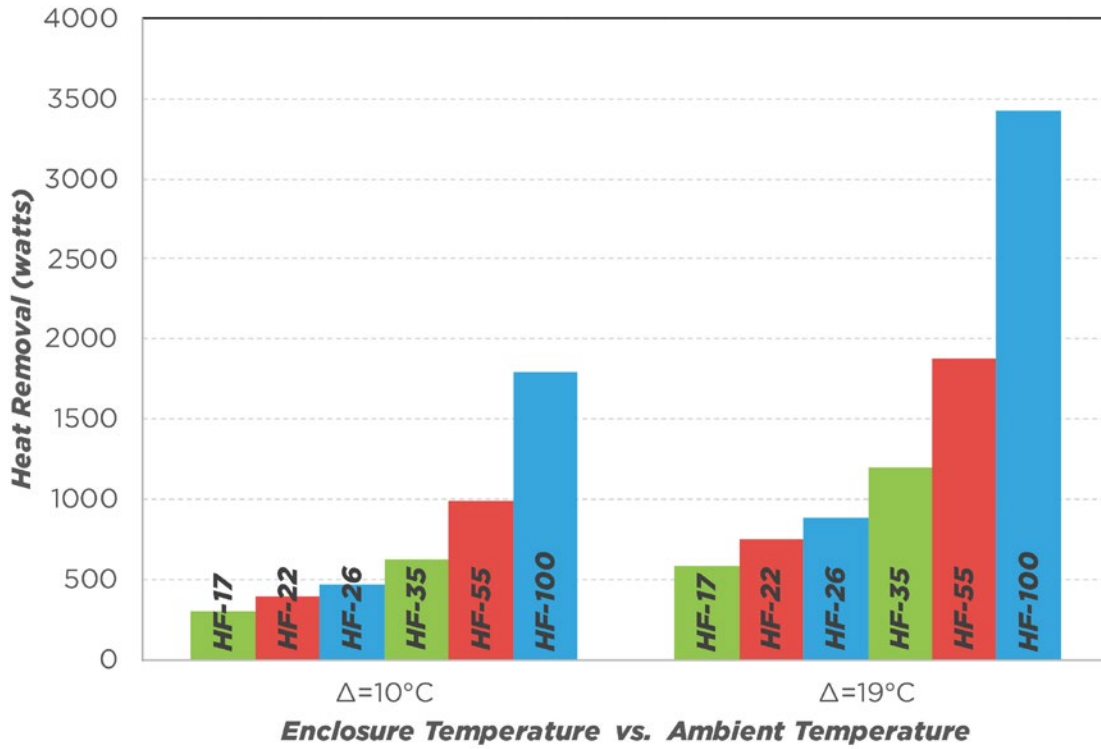

- NOTES:
 1) UNITS = MM [IN]
 2) STEP FILES AVAILABLE ON REQUEST

HexFlow® 100

Technical Data

	UNITS		
MODEL NUMBER	--	HF-100-230	HF-100-48
MOUNTING TYPE	--	Outdoor	
UNIT DIMENSIONS [HxWxD]	Inches [mm]	60x24x14 [1524x609.6x355.6]	
WEIGHT	Lbs [kg]	135 [61.4]	
COOLING CAPACITY 131°F INTERNAL / 131°F AMBIENT	W/°F [W/°C]	100 [180]	
OPERATIONAL TEMPERATURE RANGE	°F [°C]	-40 to 149 [-40 to 65]	
NOISE 1.5M DISTANCE	dB	69	
INPUT VOLTAGE	Volts	230 VAC	48V DC
CURRENT	Amps	1.0	5.0
APPROVALS	--	SA12349 (UL)	
CONSTRUCTION	--	Aluzink Steel, Stainless Optional Textured Powder Coat, Color Options Available	

HexFlow® 200

Capacity Curve & Dimensional Drawings

Heat Removal at Recommended ΔT

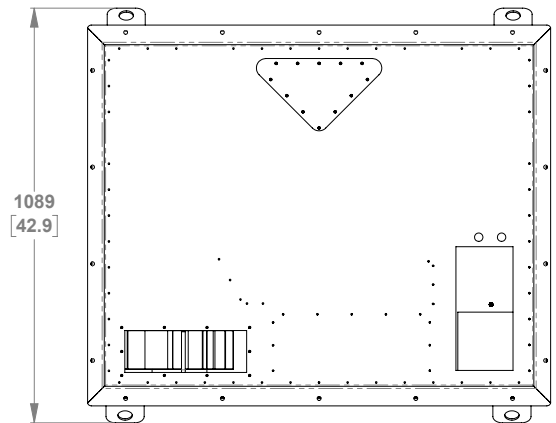
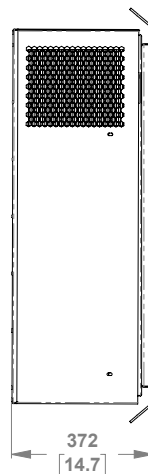
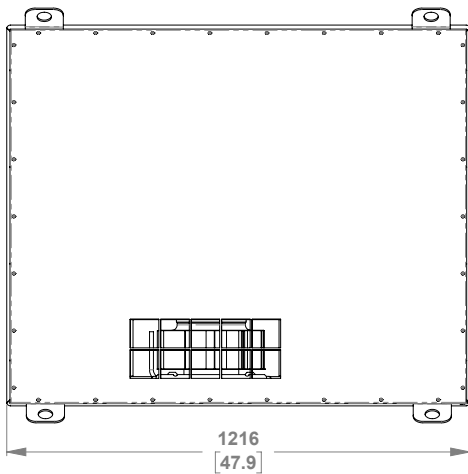
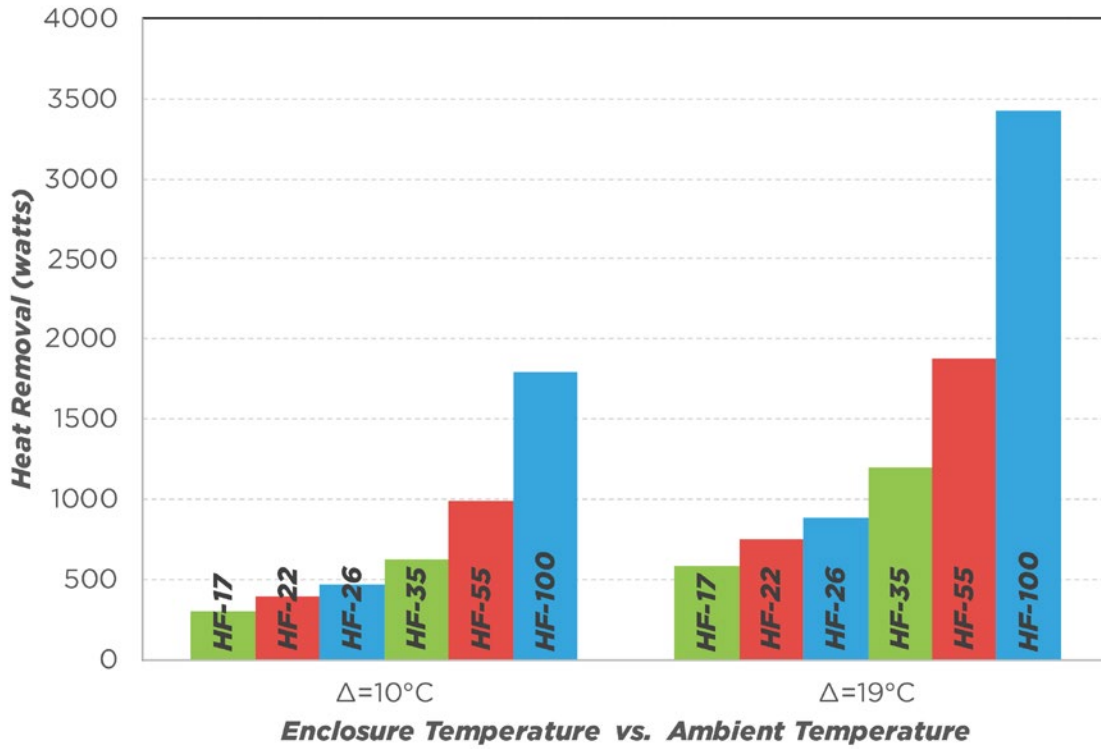

- NOTES:
 1) UNITS = MM [IN]
 2) STEP FILES AVAILABLE ON REQUEST

HexFlow® 200

Technical Data

	UNITS	
MODEL NUMBER	--	HF-200-460/3
MOUNTING TYPE	--	Roof Top
UNIT DIMENSIONS [HxWxD]	Inches [mm]	14.2x47x38.6 [361x1195x980]
WEIGHT	Lbs [kg]	250 [113]
COOLING CAPACITY 131°F INTERNAL / 131°F AMBIENT	W/°F [W/°C]	200 [360]
OPERATIONAL TEMPERATURE RANGE	°F [°C]	-40 to 149 [-40 to 65]
NOISE 1.5M DISTANCE	dB	81
INPUT VOLTAGE	Volts	460/3 VAC
CURRENT	Amps	4.0
APPROVALS	--	SA12349 (UL)
CONSTRUCTION	--	Aluzink Steel, Stainless Optional Textured Powder Coat, Color Options Available

DANTHERM
COOLING

DANTHERMCOOLING.COM

TECH.SUPPORT@DANTHERMCOOLING.COM 864-595-9800

671 SPRINGFIELD ROAD SPARTANBURG, SOUTH CAROLINA 29303