



## **PrecisionAir® Series**

*Performance Electrical Cabinet HVAC and Heat Pump Cooling Systems*



**DANTHERMCOOLING.COM**

TECHSUPPORT@DANTHERMCOOLING.COM | 864-595-9800

671 SPRINGFIELD ROAD | SPARTANBURG, SOUTH CAROLINA 29303



## ***About Dantherm Cooling***

### *Performance Cooling*

Over the past 28 years, Dantherm cooling has established itself as a leader in innovative cooling systems, supplying more than 300,000 climate control units to mission critical applications. By applying our passion for performance and quality throughout our company, we have become known for providing outstanding products and an exceptional customer experience.

Our innovative, highly engineered product lines feature industry leading technology to deliver outstanding performance, operate efficiently and perform reliably in extreme climate conditions. Backed by our experienced design team, quality manufacturing processes and extensive testing and certification practices, Dantherm Cooling can provide customers with engineered solutions to their most challenging applications.

Our passion and success in building an industry leading business compels us to invest in those around us. From our employee centric culture, to our ongoing community outreach, we are committed to use our business as a catalyst for positivity in the lives of those around us.

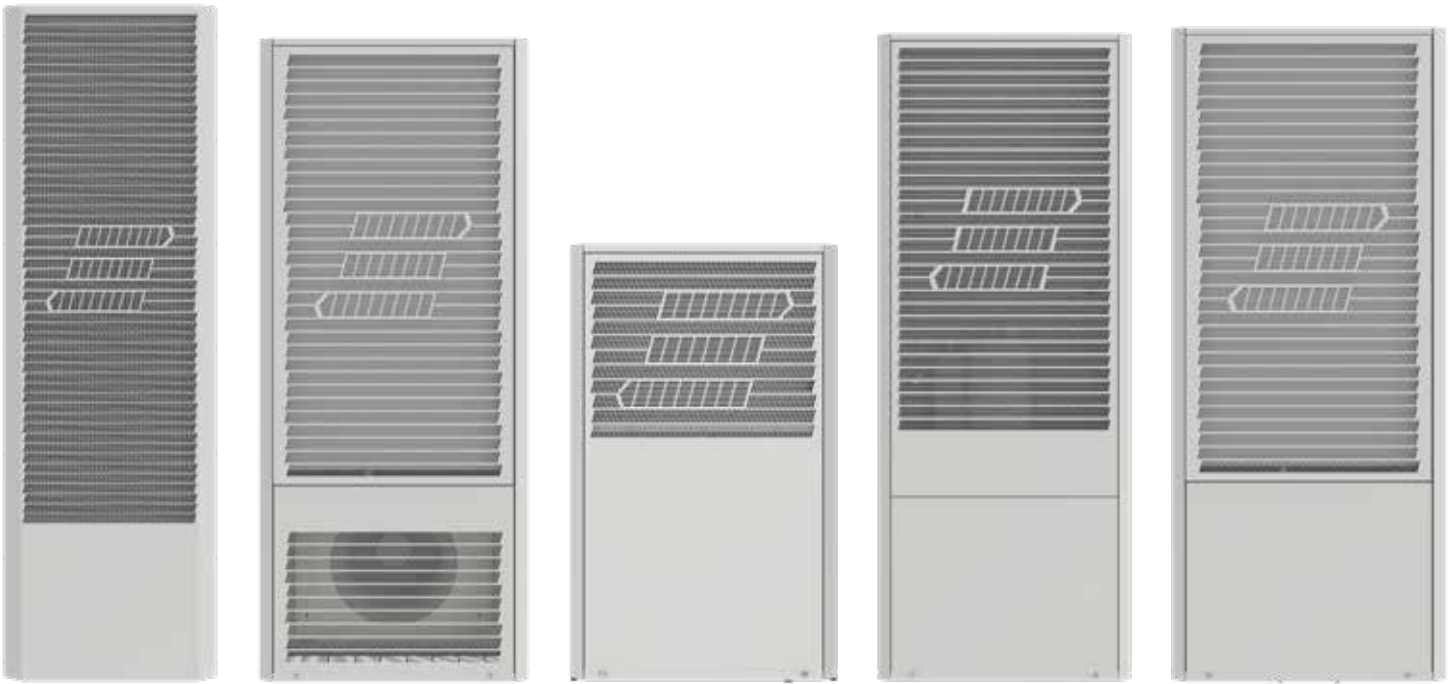

## **PrecisionAir<sup>®</sup>**

PrecisionAir cabinet cooling systems are designed with performance in mind. Our systems draw warm air from the top of a cabinet or enclosure, then transfer the heat out, and return cool air to the bottom of the enclosure while ensuring that dust, contaminants, and moisture stay out. Closed-loop technology helps maintain a clean internal environment with minimum maintenance, for optimal performance and maximum service life of the electronics inside the cabinet or enclosure. As a result, PrecisionAir units deliver superior cooling, far outperforming commercial air conditioning units.

Dantherm PrecisionAir cabinet cooling systems are easy to install and engineered for use in a wide range of cooling capacities. Having been widely installed on mission-critical equipment and in digital infrastructure applications, customers have grown to trust their proven reliability and exceptional performance.

A wide range of options, capacities and features along with refined manufacturing processes make the PrecisionAir series adaptable for a wide range of critical infrastructure applications where performance and reliability are of the utmost concern.

## **PrecisionAir®**

### *Energy Efficient Cooling For Any Equipment Enclosure*

At Dantherm Cooling, innovation is a critical part of who we are. In fact, pursuing innovation is one of our core values. Our PrecisionAir cabinet cooling systems utilize our extensive engineering and manufacturing expertise to deliver energy-efficient cooling for any equipment enclosure.

All of our products are manufactured to exacting tolerances and thoroughly tested before they leave our factory. With over 300,000 units operating in mission critical applications, customers can be assured of long life and industry leading performance.

- Compact, self-contained design for easy installation in indoor and outdoor applications
- Closed-loop cooling prevents ingress of contaminants
- High-performance BCI fans have high-static pressure capability for improved air flow while reducing noise and energy usage
- Bottom outside air loop intake allows for reduced noise and better protection from contaminants
- Easy access to critical components for better serviceability
- Integrated ACG7 controller available with ethernet featuring SNMP Ver2 or Modbus with web-based GUI

## **Engineered Performance**

### *Designed to Meet Demanding Customer Requirements*

#### **Energy Efficient**

Engineered performance with high-static BCI fans uses 40-60% less energy

#### **Optimized Cooling**

Powerful cooling designed to perform in high ambient temperatures

#### **Quiet Performance**

Designed to reduce noise, making PrecisionAir ideal for sound-sensitive applications at 60-65 dB



#### **Reliable**

Closed loop design, all aluminum microchannel coil and weatherproof enclosure for the most challenging environments

#### **Connected**

Monitor and manage thermal environment from your desk with integrated ACG7 Smart Controller

#### **Low Maintenance**

Easy to install with minimal maintenance requirements

## **PrecisionAir®**

*Verified Performance, Quality Assured*

Dantherm Cooling's commitment to high-quality innovation, manufacturing and customer support is demonstrated by the standards we keep.

Our products are routinely used in critical infrastructure applications where our customers require the highest performance, quality and reliability standards. Third party certification and verification gives customers a sense of security knowing that our products have been independently tested to perform to the caliber we claim.



Dantherm Cooling's ISO 9001:2105 certification demonstrates that our business and manufacturing processes meet all international standards for the consistent delivery of high-quality products and services. Regular audits and process reviews ensure consistent manufacturing performance.



Through our partnership with Underwriter's Laboratory (UL), UL has certified that all Dantherm Cooling materials and products, as well as specific testing procedures and documentation, have been thoroughly inspected for safety and quality, and meet or exceed established standard requirements.



## **PrecisionAir®**

*Engineered for a Wide Variety of Applications*

### **Telecom**

PrecisionAir units from Dantherm are ideally suited for telecom buildings which require energy efficient cooling for the valuable electronic equipment held inside. Dantherm Cooling units offer improved design techniques and high quality components to optimize cooling performance and energy efficiency while requiring little maintenance.



### **Battery Energy Storage (BESS)**

Battery energy storage applications require reliable performance cooling to improve storage conditions and optimize battery life. Dantherm's PrecisionAir units offer reliable performance, high quality BCI fans and Dantherm's integrated ACG7 controller to offer consistent ideal temperatures, improving the performance of your system.



### **Electric Grid T&D Control Houses**

Demanding electric grid relay switching T&D control houses require sufficient thermal control to keep equipment running smoothly. PrecisionAir units are designed to operate efficiently in extreme conditions, weather and the wide-range of outdoor environments energy professionals must operate in.



# DANTHERM

COOLING

## PrecisionAir®

*Technical Specifications*



# PrecisionAir®

## Configure Your Own PrecisionAir System

PrecisionAir cabinet cooling systems offer a wide variety of options with versatility for a number of applications and conditions in mind. A number of product options are available allowing each unit to be tailored specifically for the application in which it will be applied.

All of our products are manufactured to exacting tolerances and thoroughly tested before they leave our factory. With over 300,000 units installed in the field in a variety of industries Dantherm products are proven performers.

- Multiple heater options available
- AC and DC powered units available
- Environmentally friendly R134A refrigerant
- Wide range of color and finish options

### PA-10-230-F-ET-SS-03

**CAPACITY**  
4 - 4000 BTU  
6 - 6000 BTU  
10 - 10000 BTU  
12 - 12000 BTU  
14 - 14000 BTU  
24 - 24000 BTU  
28 - 28000 BTU

**VOLTAGE**  
115 - 115 VAC  
230 - 230 VAC  
48 - 48 VDC

**OPTIONAL FILTER**  
H - STANDARD MERV8  
M - MERV13  
F - FRESH AIR

**OPTIONAL ETHERNET CONTROLLER**  
ET - ETHERNET CONTROLLER

**OPTIONAL METAL PACKAGE**  
SS - STAINLESS STEEL\*  
\*LEAVE BLANK - STANDARD GALVANIZED STEEL

**COLOR**  
03 - P03 GREY  
04 - P04 BEIGE  
20 - P20 WHITE  
00 - CUSTOM

### Color Options

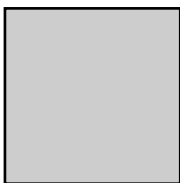

03 - P03 Grey

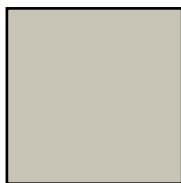

04 - P04 Beige



20 - P20 White

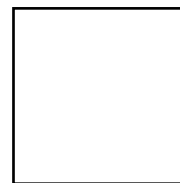

00 - Custom



# PrecisionAir® 2000

## Capacity Curve & Dimensional Drawings

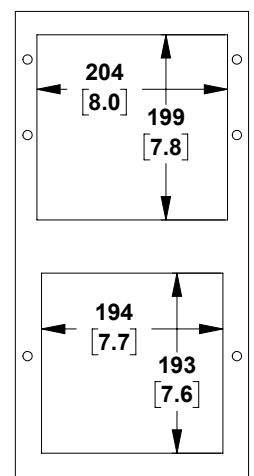
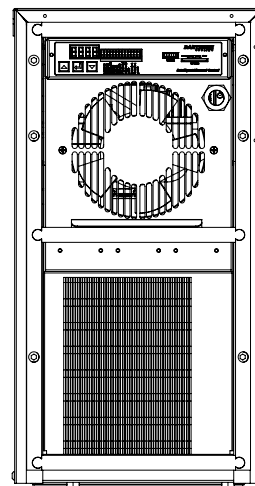
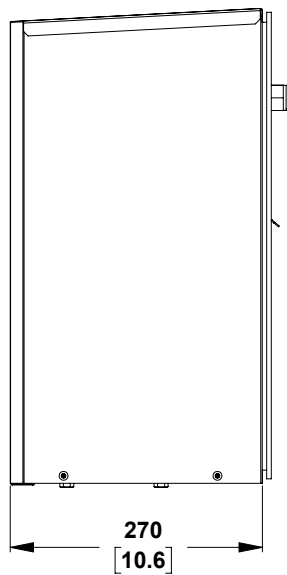
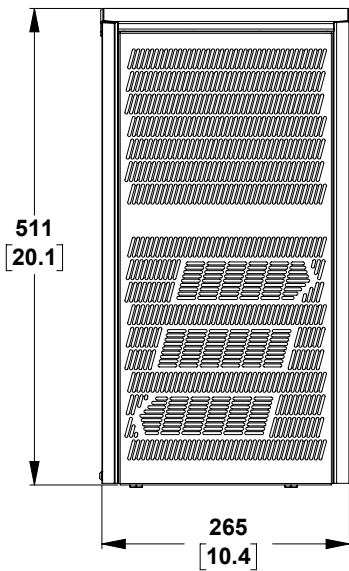
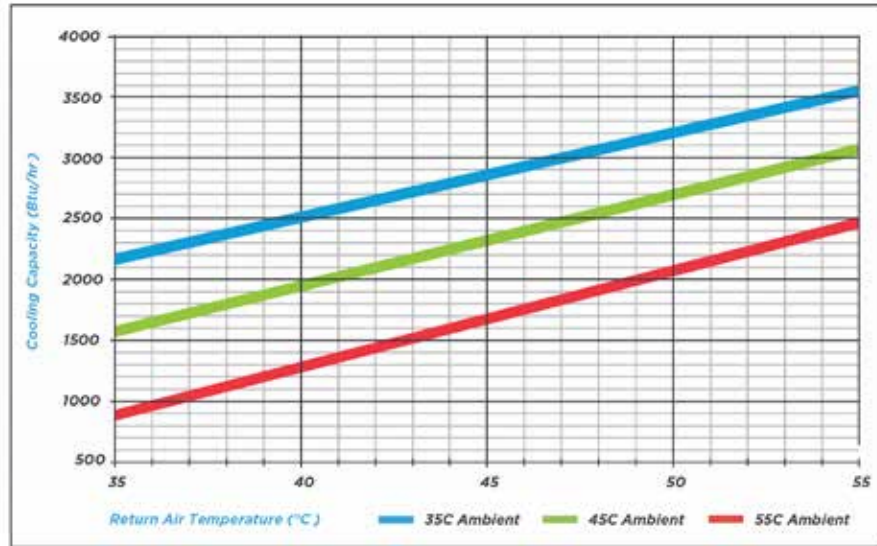
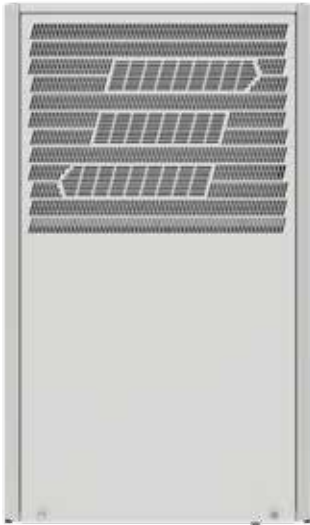

**NOTES:**

- 1) UNITS = MM [IN]
- 2) STEP FILES AVAILABLE ON REQUEST

# PrecisionAir® 2000

## Technical Data

	UNITS		
MODEL NUMBER	--	PA-2-115	PA-2-230
MOUNTING TYPE	--	Outdoor, NEMA 3R	
UNIT DIMENSIONS [HxWxD]	Inches [mm]	20.25x10.4x10.6 [514.35x264.16x269.24]	
WEIGHT	Lbs [kg]	55 [25]	
COOLING CAPACITY 131°F INTERNAL / 131°F AMBIENT	BTU/h [W]	2,480 [726]	
COOLING CAPACITY 95°F INTERNAL / 95°F AMBIENT	BTU/h [W]	2,160 [629]	
INTERNAL AIRFLOW	CFM [m³/h]	100 [170]	
EXTERNAL AIRFLOW	CFM [m³/h]	100 [170]	
REFRIGERANT/AMOUNT	Type [g]	R134a [210]	
OPERATIONAL TEMPERATURE RANGE	°F [°C]	-40 to 131 [-40 to 55]	
NOISE 1.5M DISTANCE	dB	64	
HEATER	Watts	500	
INPUT VOLTAGE /FREQUENCY	Volts/Hz	115/230 VAC 50/60 Hz	
POWER CONSUMPTION	Amps	8.0	4.0
APPROVALS	--	SA10718 (UL)	
CONSTRUCTION	--	Galvanized Steel, Stainless Optional Textured Powder Coat, Color Options Available	

# PrecisionAir® 4000

## Capacity Curve & Dimensional Drawings

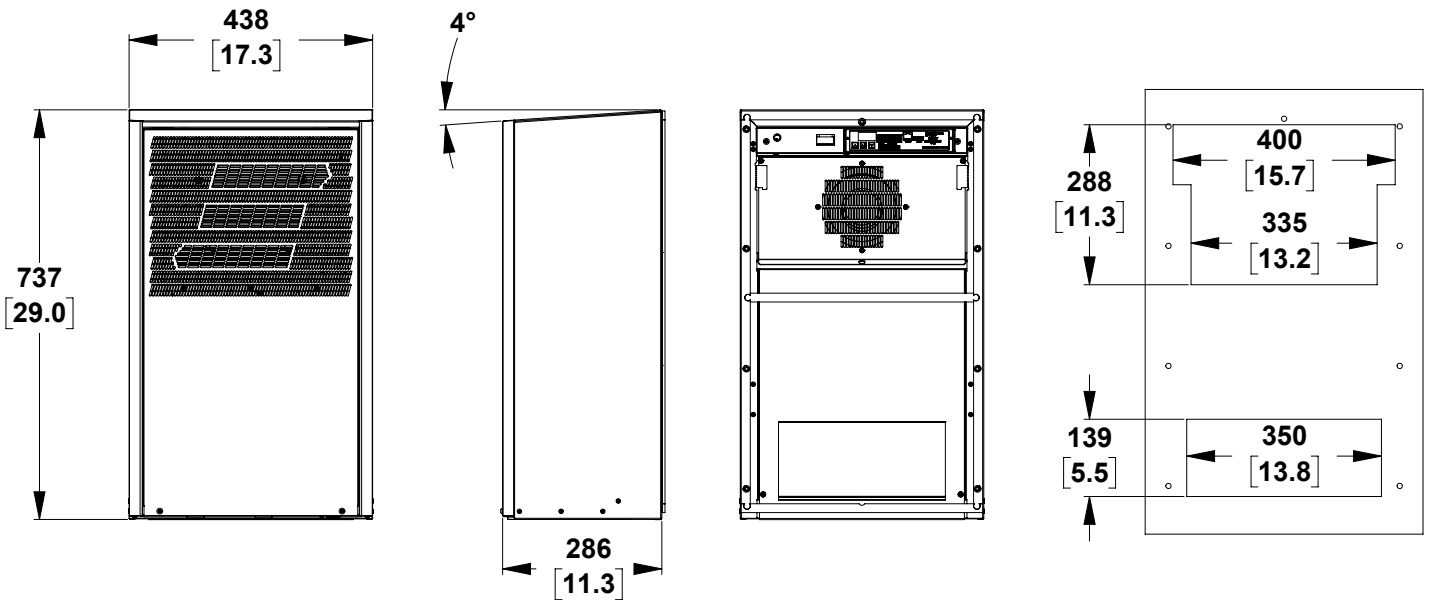
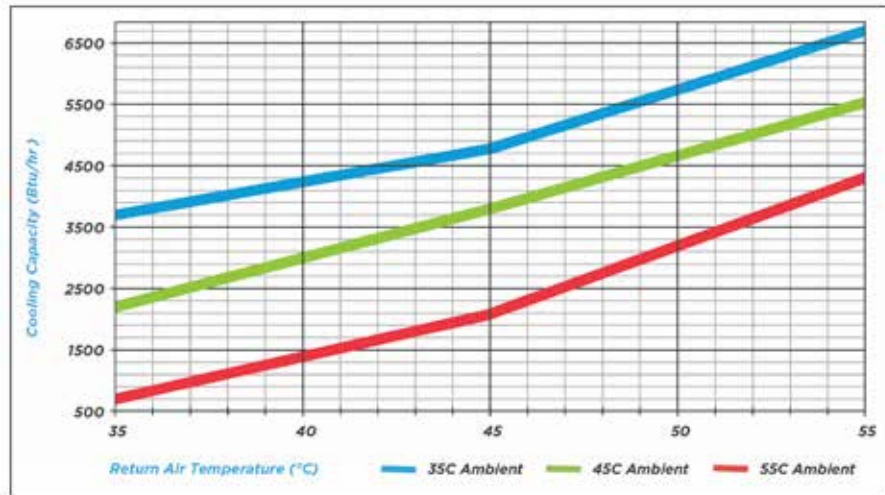
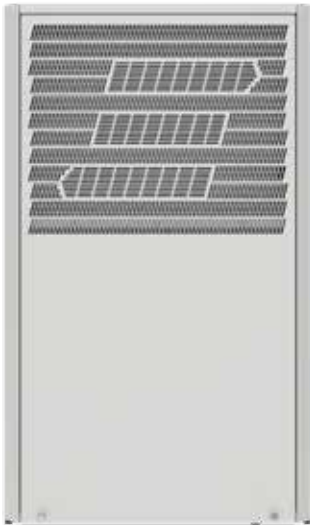

**NOTES:**

- 1) UNITS = MM [IN]
- 2) STEP FILES AVAILABLE UPON REQUEST

# PrecisionAir® 4000

## Technical Data

	UNITS				
MODEL NUMBER	--	PA-4-115	PA-4-230	PA-4-460/3	PA-4-48
MOUNTING TYPE	--	Outdoor, NEMA 3R			
UNIT DIMENSIONS [HxWxD]	Inches [mm]	29.0x17.3x11.3 [737x439x286]			
WEIGHT	Lbs [kg]	75 [34]		90 [41]	
COOLING CAPACITY 131°F INTERNAL / 131°F AMBIENT	BTU/h [W]	4,270 [1,250]		4,200 [1,230]	
COOLING CAPACITY 95°F INTERNAL / 95°F AMBIENT	BTU/h [W]	4235 [1,240]		4000 [1,170]	
INTERNAL AIRFLOW	CFM [m <sup>3</sup> /h]	247 [420]			
EXTERNAL AIRFLOW	CFM [m <sup>3</sup> /h]	247 [420]			
REFRIGERANT/AMOUNT	Type [g]	R134a [210]			
OPERATIONAL TEMPERATURE RANGE	°F [°C]	-40 to 131 [-40 to 55]			
NOISE 1.5M DISTANCE	dB	<62		<65	
HEATER	Watts	1,000		500	
INPUT VOLTAGE /FREQUENCY	Volts/Hz	115 VAC 60 Hz	230 VAC 50/60 Hz	460 VAC 50/60 Hz	48 VDC +15%/-20%
POWER CONSUMPTION	Amps	8.9	5.8	2.3	12.0
APPROVALS	--	4010388 (ETL)			SA10718 (UL)
CONSTRUCTION	--	Galvanized Steel, Stainless Optional Textured Powder Coat, Color Options Available			

# PrecisionAir® 6000

## Capacity Curve & Dimensional Drawings

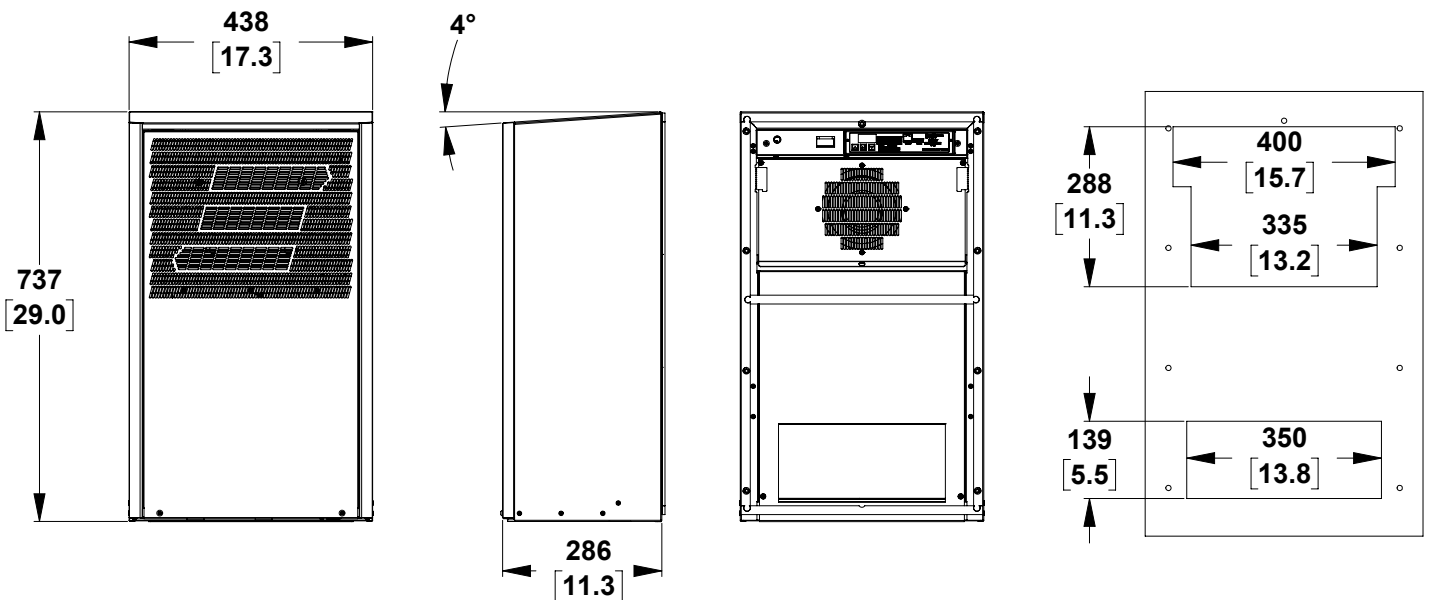
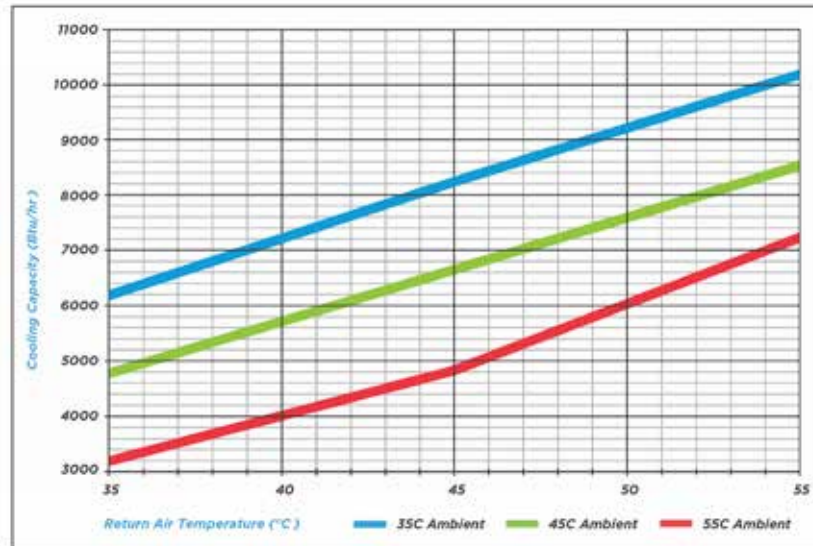
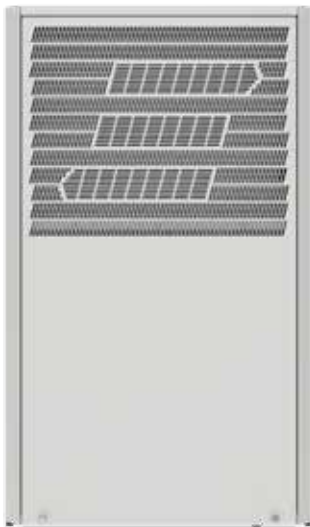

**NOTES:**

- 1) UNITS = MM [IN]
- 2) STEP FILES AVAILABLE UPON REQUEST

# PrecisionAir® 6000

## Technical Data

	UNITS				
MODEL NUMBER	--	PA-6-115	PA-6-230	PA-6-460/3	PA-6-48
MOUNTING TYPE	--	Outdoor, NEMA 3R			
UNIT DIMENSIONS [HxWxD]	Inches [mm]	29.0x17.3x11.3 [737x439x286]			
WEIGHT	Lbs [kg]	80 [36]			95 [43]
COOLING CAPACITY 131°F INTERNAL / 131°F AMBIENT	BTU/h [W]	6,000 [1,750]			
COOLING CAPACITY 95°F INTERNAL / 95°F AMBIENT	BTU/h [W]	6,170 [1,806]			
INTERNAL AIRFLOW	CFM [m³/h]	247 [420]			
EXTERNAL AIRFLOW	CFM [m³/h]	247 [420]			
REFRIGERANT/AMOUNT	Type [g]	R134a [500]			
OPERATIONAL TEMPERATURE RANGE	°F [°C]	-40 to 131 [-40 to 55]			
NOISE 1.5M DISTANCE	dB	<65			
HEATER	Watts	1,000			500
INPUT VOLTAGE /FREQUENCY	Volts/Hz	115 VAC 60 Hz	230 VAC 50/60 Hz	460 VAC 50/60 Hz	48 VDC +15%/-20%
POWER CONSUMPTION	Amps	10.0	7.0	3.0	16.0
APPROVALS	--	4010388 (ETL)			SA10718 (UL)
CONSTRUCTION	--	Galvanized Steel, Stainless Optional Textured Powder Coat, Color Options Available			



# PrecisionAir® 10000, 12000, 14000

## Capacity Curve & Dimensional Drawings

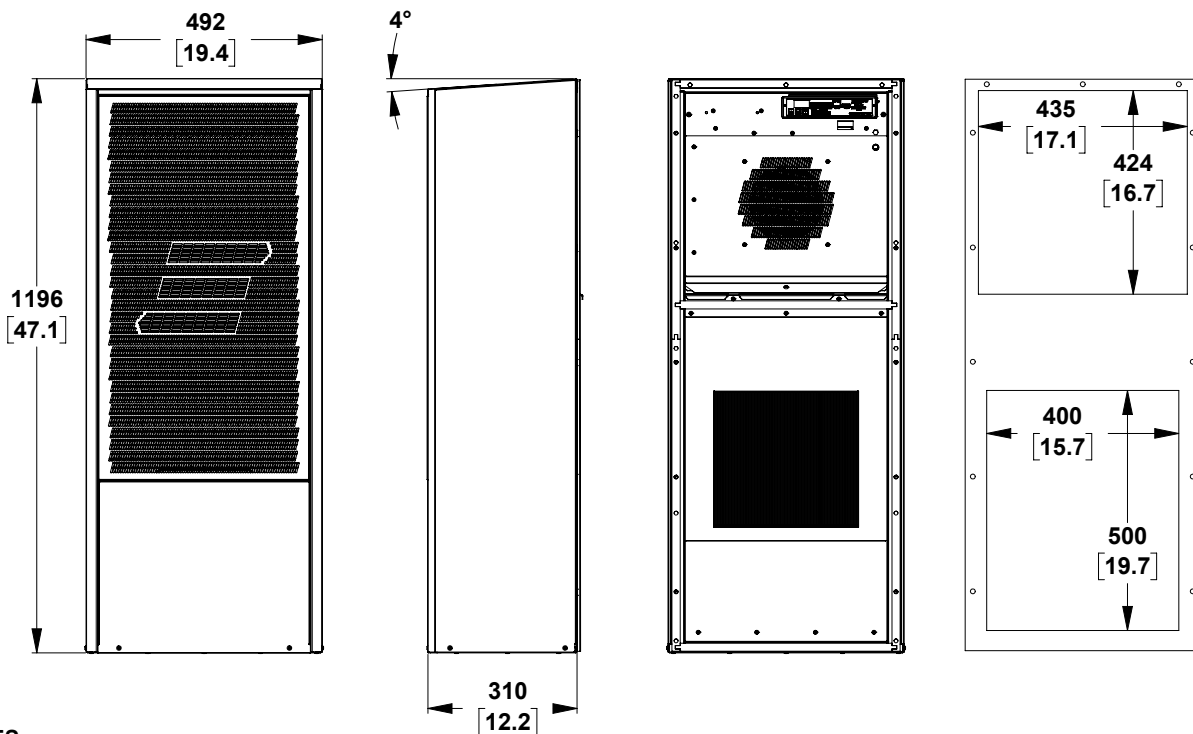
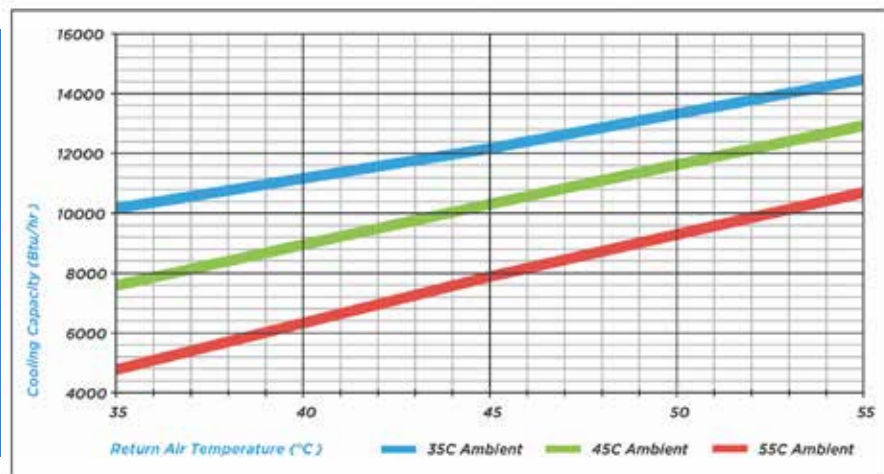

- NOTES:**  
 1) UNITS = MM [IN]  
 2) STEP FILES AVAILABLE UPON REQUEST

# PrecisionAir® 10000, 12000, 14000

## Technical Data

	UNITS					
MODEL NUMBER	--	PA-10-230	PA-10-48	PA-12-230	PA-12-48	PA-14-48
MOUNTING TYPE	--	Outdoor, NEMA 3R				
UNIT DIMENSIONS [HxWxD]	Inches [mm]	47.3x19.3x12.2 [1201x490x309]				
WEIGHT	Lbs [kg]	115 [52]				
COOLING CAPACITY 131°F INTERNAL / 131°F AMBIENT	BTU/h [W]	10,700 [3,133]		11,300 [3,000]		14,000 [4,100]
COOLING CAPACITY 95°F INTERNAL / 95°F AMBIENT	BTU/h [W]	10,170 [2,977]		10,300 [3,000]		12,100 [3,545]
INTERNAL AIRFLOW	CFM [m³/h]	210 to 450 [765]				
EXTERNAL AIRFLOW	CFM [m³/h]	400 to 710 [1,205]				
REFRIGERANT/AMOUNT	Type [g]	R134a [500]				
OPERATIONAL TEMPERATURE RANGE	°F [°C]	-40 to 131 [-40 to 55]				
NOISE 1.5M DISTANCE	dB	60 to 65				
HEATER	Watts	2,000	500	2,000	500	
INPUT VOLTAGE /FREQUENCY	Volts/Hz	208/230 VAC 50/60 Hz	48 VDC, +20%/-15%	208/230 VAC 50/60 Hz	48 VDC, +20%/-15%	
POWER CONSUMPTION	Amps	11.0	29.0	11.0	29.0	27.0
APPROVALS	--	SA10718 (UL)				
CONSTRUCTION	--	Galvanized Steel, Stainless Optional Textured Powder Coat, Color Options Available				

# PrecisionAir® 14000 Mid Mount

## Capacity Curve & Dimensional Drawings

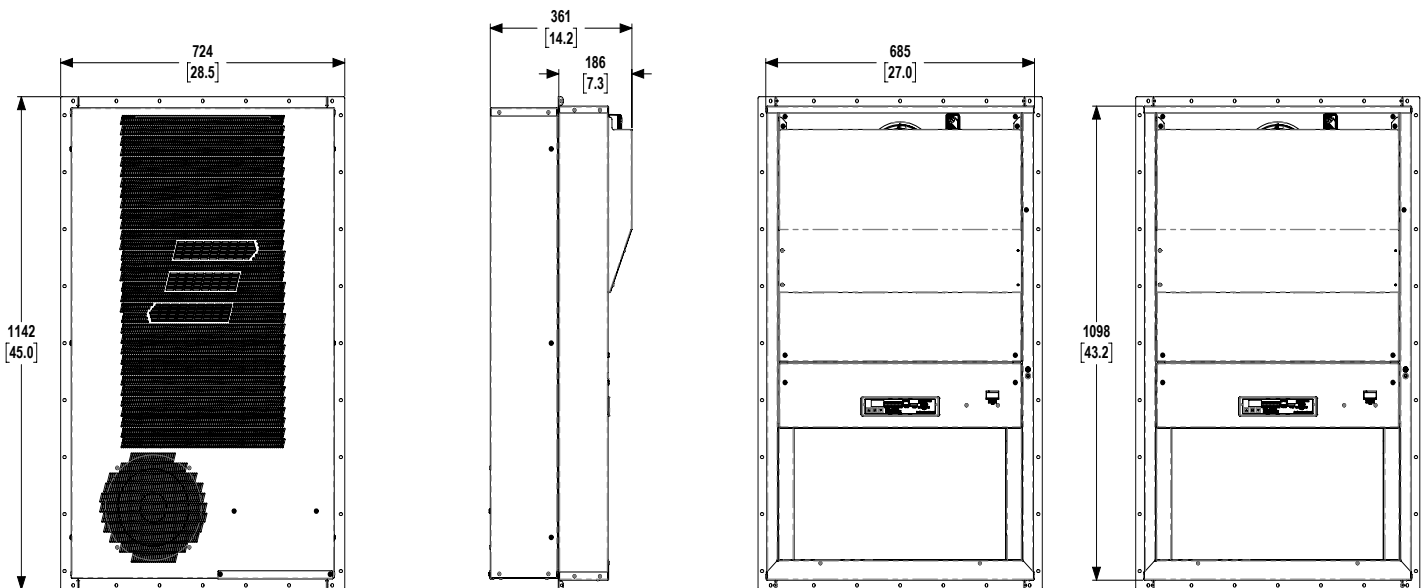
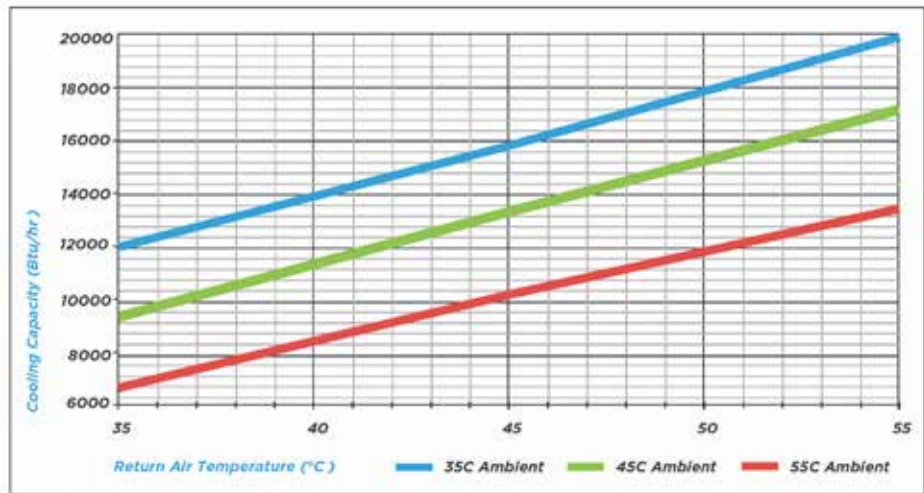

**NOTES:**

- 1) UNITS = MM [IN]
- 2) STEP FILES AVAILABLE UPON REQUEST

# PrecisionAir® 14000 Mid Mount

## Technical Data

	UNITS	
MODEL NUMBER	--	PA-14-48-MM
MOUNTING TYPE	--	Outdoor, NEMA3R
UNIT DIMENSIONS [HxWxD]	Inches [mm]	42.9x26.3x11.1 [1089x668x282]
WEIGHT	Lbs [kg]	115 [52]
COOLING CAPACITY 131°F INTERNAL / 131°F AMBIENT	BTU/h [W]	14,000 [4,100]
COOLING CAPACITY 95°F INTERNAL / 95°F AMBIENT	BTU/h [W]	12,100 [3,545]
INTERNAL AIRFLOW	CFM [m³/h]	210 to 450 [765]
EXTERNAL AIRFLOW	CFM [m³/h]	400 to 710 [1,205]
REFRIGERANT/AMOUNT	Type [g]	R134a [500]
OPERATIONAL TEMPERATURE RANGE	°F [°C]	-40 to 131 [-40 to 55]
NOISE 1.5M DISTANCE	dB	60 to 65
HEATER	Watts	500
INPUT VOLTAGE /FREQUENCY	Volts/Hz	48 VDC, +20%/-15%
POWER CONSUMPTION	Amps	27.0
APPROVALS	--	SA10718 (UL)
CONSTRUCTION	--	Galvanized Steel, Stainless Optional Textured Powder Coat, Color Options Available

# PrecisionAir® 20000

## Capacity Curve & Dimensional Drawings

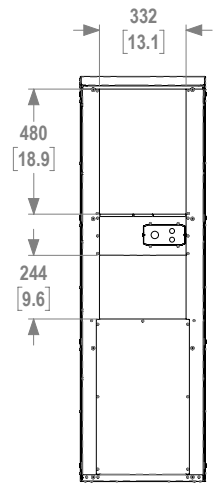
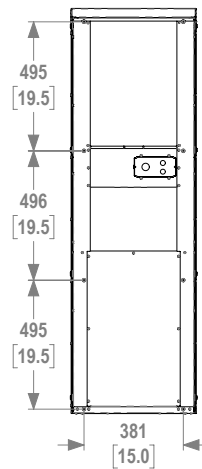
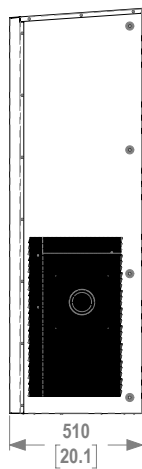
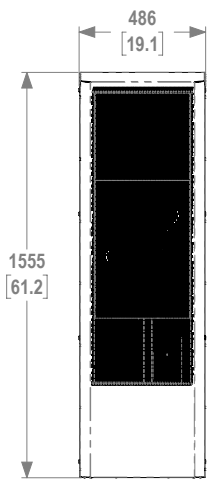
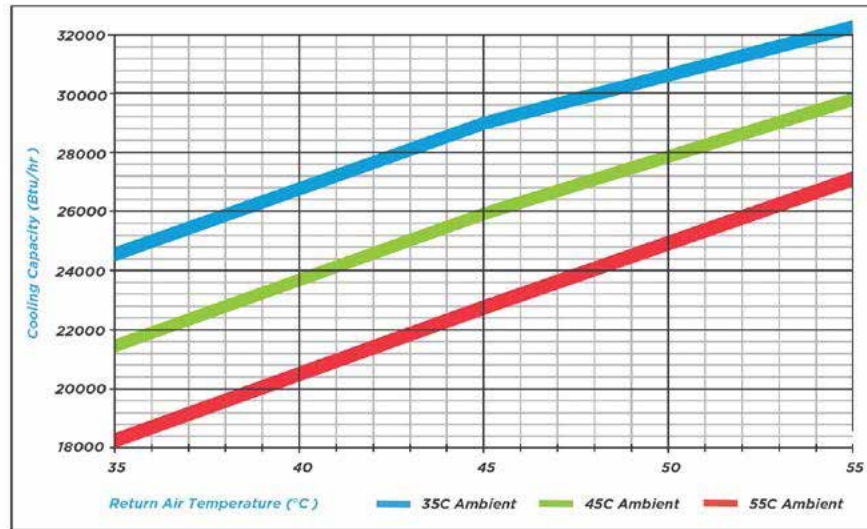
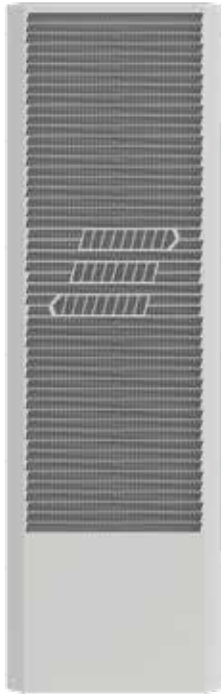

**NOTES:**

- 1) UNITS = MM [IN]
- 2) STEP FILE AVAILABLE UPON REQUEST

# PrecisionAir® 20000

## Technical Data

	UNITS	
MODEL NUMBER	--	PA-20-230
MOUNTING TYPE	--	Outdoor, NEMA 3R
UNIT DIMENSIONS [HxWxD]	Inches [mm]	61x19x20 [1549x483x508]
WEIGHT	Lbs [kg]	200 [91]
COOLING CAPACITY 131°F INTERNAL / 131°F AMBIENT	BTU/h [W]	20,400 [6,030]
COOLING CAPACITY 95°F INTERNAL / 95°F AMBIENT	BTU/h [W]	19,800 [5,800]
INTERNAL AIRFLOW	CFM [m³/h]	1,250 [2,120]
EXTERNAL AIRFLOW	CFM [m³/h]	1,250 [2,120]
REFRIGERANT/AMOUNT	Type [g]	R134a [500]
OPERATIONAL TEMPERATURE RANGE	°F [°C]	-40 to 131 [-40 to 55]
NOISE 1.5M DISTANCE	dB	60 to 65
HEATER	Watts	2,000
INPUT VOLTAGE /FREQUENCY	Volts/Hz	208/230 VAC 50/60 Hz
POWER CONSUMPTION	Amps	15.0
APPROVALS	--	SA10718 (UL)
CONSTRUCTION	--	Galvanized Steel, Stainless Optional Textured Powder Coat, Color Options Available



# PrecisionAir® 24000

## Capacity Curve & Dimensional Drawings

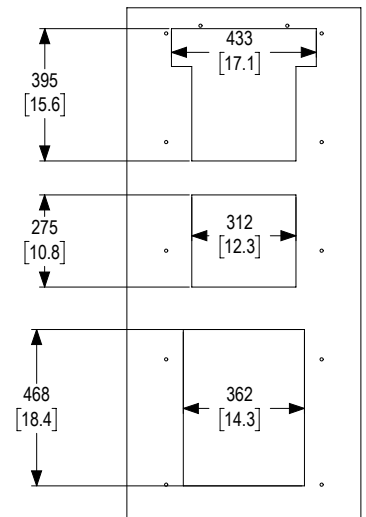
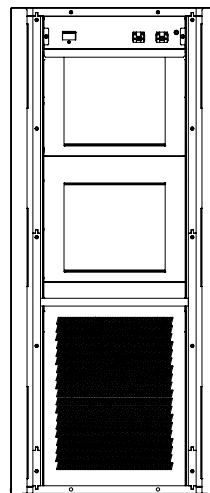
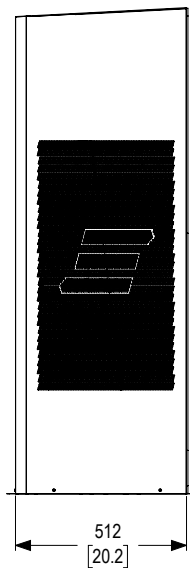
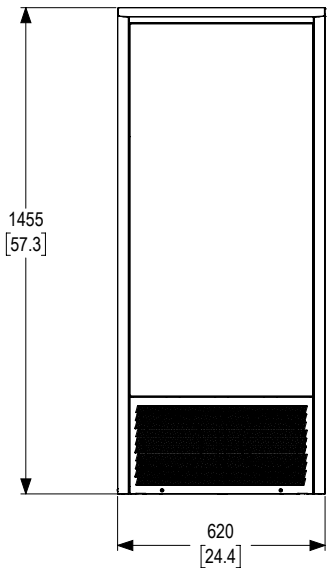
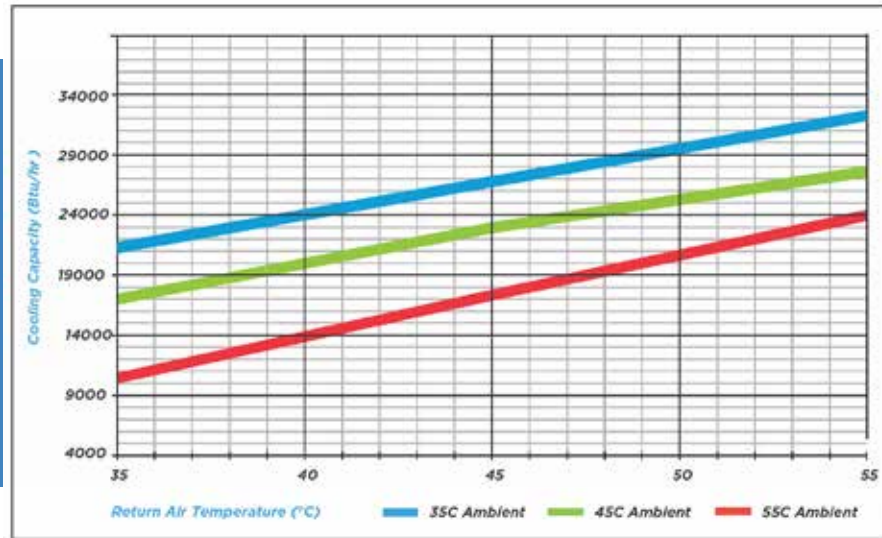

**NOTES:**

- 1) UNITS = MM [IN]
- 2) STEP FILES AVAILABLE UPON REQUEST

# PrecisionAir® 24000

## Technical Data

	UNITS		
MODEL NUMBER	--	PA-24-230	PA-24-48
MOUNTING TYPE	--	Outdoor, NEMA 3R	
UNIT DIMENSIONS [HxWxD]	Inches [mm]	59x24.3x20.2 [1499x617x513]	
WEIGHT	Lbs [kg]	230 [104]	
COOLING CAPACITY 131°F INTERNAL / 131°F AMBIENT	BTU/h [W]	24,000 [7,000]	
COOLING CAPACITY 95°F INTERNAL / 95°F AMBIENT	BTU/h [W]	22,000 [6,400]	
INTERNAL AIRFLOW	CFM [m³/h]	800 [1,360]	
EXTERNAL AIRFLOW	CFM [m³/h]	1,400 [2,380]	
REFRIGERANT/AMOUNT	Type [g]	R134a [1200]	
OPERATIONAL TEMPERATURE RANGE	°F [°C]	-40 to 131 [-40 to 55]	
NOISE 1.5M DISTANCE	dB	65	
HEATER	Watts	2,000	1,000
INPUT VOLTAGE /FREQUENCY	Volts/Hz	208/230 VAC 50/60 Hz	48 VDC, +20%/-15%
POWER CONSUMPTION	Amps	20.0	60.0
APPROVALS	--	SA10718 (UL)	
CONSTRUCTION	--	Galvanized Steel, Stainless Optional Textured Powder Coat, Color Options Available	

# PrecisionAir® 28000

## Capacity Curve & Dimensional Drawings

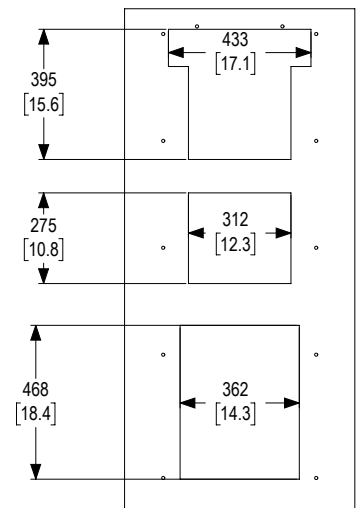
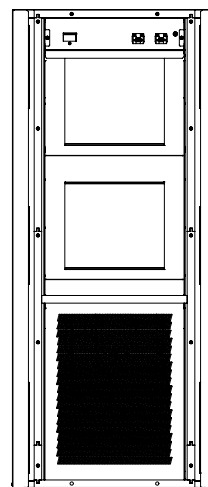
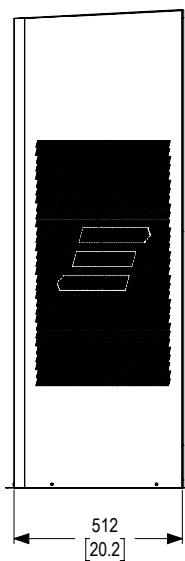
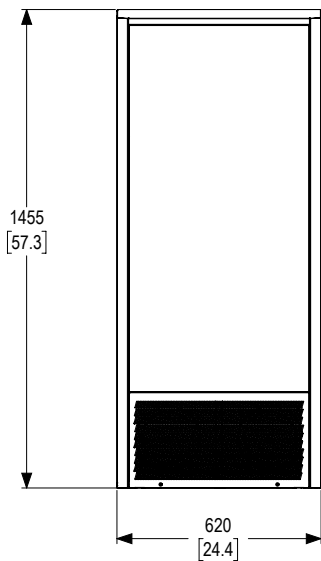
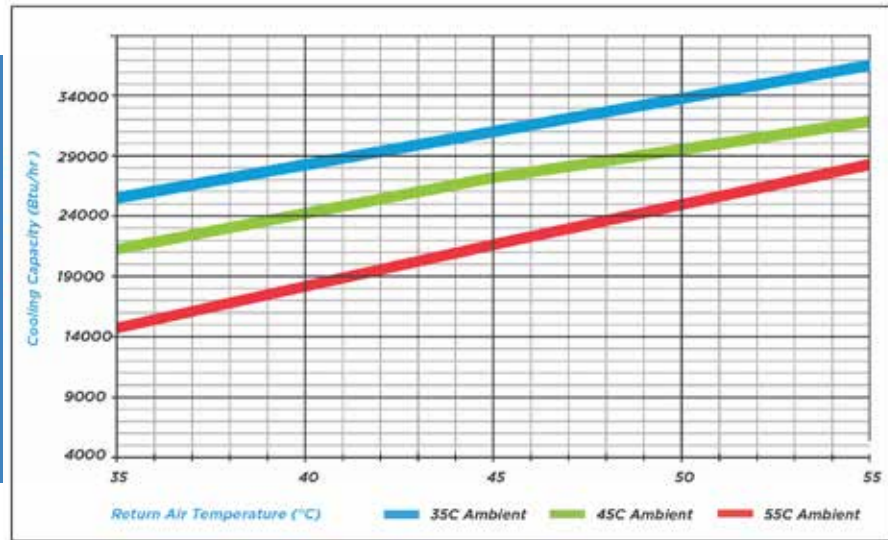

- NOTES:**  
 1) UNITS = MM [IN]  
 2) STEP FILE AVAILABLE UPON REQUEST

# PrecisionAir® 28000

## Technical Data

	UNITS	
MODEL NUMBER	--	PA-28-48
MOUNTING TYPE	--	Outdoor, NEMA 3R
UNIT DIMENSIONS [HxWxD]	Inches [mm]	59x24.3x20.2 [1499x617x513]
WEIGHT	Lbs [kg]	230 [104]
COOLING CAPACITY 131°F INTERNAL / 131°F AMBIENT	BTU/h [W]	28,000 [8,200]
COOLING CAPACITY 95°F INTERNAL / 95°F AMBIENT	BTU/h [W]	26,000 [7,600]
INTERNAL AIRFLOW	CFM [m³/h]	800 [1,360]
EXTERNAL AIRFLOW	CFM [m³/h]	1,400 [2,380]
REFRIGERANT/AMOUNT	Type	R134a [1,200]
OPERATIONAL TEMPERATURE RANGE	°F [°C]	-40 to 131 [-40 to 55]
NOISE 1.5M DISTANCE	dB	65
HEATER	Watts	1,000
INPUT VOLTAGE /FREQUENCY	Volts/Hz	48 VDC, +20%/-15%
POWER CONSUMPTION	Amps	60.0
APPROVALS	--	SA10718 (UL)
CONSTRUCTION	--	Galvanized Steel, Stainless Optional Textured Powder Coat, Color Options Available

**DANTHERM**  
COOLING

**DANTHERMCOOLING.COM**

**TECHSUPPORT@DANTHERMCOOLING.COM 864-595-9800**

**671 SPRINGFIELD ROAD SPARTANBURG, SOUTH CAROLINA 29303**